

**GANG-NAIL®**

# FIXING & BRACING GUIDELINES FOR TIMBER ROOF TRUSSES

The Roof Trusses you are about to install have been manufactured to engineering standards. To ensure that the trusses perform, it is essential that they be handled, erected and braced correctly.



**MiTek®**  
**MiTek®**

creating the **advantage**

JANUARY 2007

To find out more about MiTek's products & systems, call your local state office or visit our web site: [www.mitek.com.au](http://www.mitek.com.au)  
VIC (03) 8795 8888 NSW (02) 8525 8000 QLD (07) 3268 1666 SA (08) 8234 1326 WA (08) 9411 2845 NZ (09) 274 7109 MALAYSIA (603) 3176 7473

HOME OF GANG-NAIL BUILDING SYSTEMS

## General

The roof trusses you are about to install have been manufactured to engineering standards. To ensure that the trusses perform as designed it is essential that they be handled, erected and braced correctly. The installation of prefabricated timber trusses is covered by the Australian Standard AS4440-2004 "Installation of nailplated timber trusses". The following information is an abbreviated set of instructions designed to assist with on site work and is not intended to replace the need to reference AS4440-2004. The following recommendations apply to roof trusses on standard domestic buildings where truss design details are obtained from MiTek engineering programs. Details for commercial, industrial and non standard domestic buildings, are to be provided by an Engineer responsible for the overall building design.

## Design

1. Trusses are designed for normal roof, ceiling and wind loads to suit specific jobs and conditions. Additional loading such as Solar Units, Hot Water Tanks, Air Conditioning, etc. require special consideration. Advice should be sought from the truss fabricator prior to commencing construction.
2. Wall frames and beams supporting trusses must be designed for the correct roof loads. Refer AS1684 "Residential Timber-Framed Construction" for details.
3. Wind load is an important factor in the design and performance of roof trusses. Ensure that you have correctly advised the truss fabricator with regard to wind load requirements and that adequate provision has been made to fix trusses to the support structure to withstand wind uplift forces.
4. Trusses are generally designed to be supported on the outer wall with inner walls being non load bearing. Where it is necessary to use internal walls for load bearing, these will be clearly shown on layouts.
5. Before ordering trusses, ensure that your particular requirements have been provided for and that all relevant information has been supplied to the truss manufacturer. If non standard trusses are being used, ensure that erection and bracing details are known before erection commences.
6. For environments where the atmosphere may be conducive to corrosion, such as some types of industrial and agricultural buildings, or buildings near the ocean and subject to salt spray, consideration should be given to the use of G8S stainless steel connector plates.

## Important Note

1. It is the Builder's responsibility to ensure that all relevant information required for design is provided to the fabricator at time of ordering trusses, including spans, pitches, profiles, quantities and loadings. Final confirmation of details by the fabricator with the builder is recommended prior to manufacture.
2. Trusses are designed to be part of a structural system, which includes battens/purlins, bracing, binders, fascias and the connection of these components. The full strength of trusses is not achieved until all components are installed correctly. All trusses must be braced (temporary and permanently) and stabilised throughout installation of the roof truss system. No truss should be loaded until all permanent bracing is fixed and battens/purlins are installed. Installers should not stand on any truss until all temporary bracing is fixed in place and the truss is stabilised in accordance with the following instructions.
3. As truss installation invariably involves working at heights, a risk assessment should be undertaken for each site and all relevant workplace safety practices followed. With every roof structure and job site, conditions are different. It is the builder's responsibility to consider these conditions when determining the procedures to be adopted in lifting and fixing roof components. The procedures should be discussed with all sub-contractors and employees on site and the agreed methods documented. The Housing Industry Association (HIA) has published a document called 'Safe Working Method Statement No.10' which has been found satisfactory for this purpose and suitable for many job sites. This document may be obtained from the HIA or your truss supplier.
4. Trusses are designed for specific loading, geometry and support conditions. Under no circumstances should truss timber be cut, removed or trusses be modified in any way without prior approval from the truss fabricator.
5. Make sure all bracing is permanently fixed and all bolts and brackets are tightened prior to the loading of the roof.
6. Trusses should not be used or stored where they are subjected to repeated wetting and drying as this has a detrimental effect on the strength of both timber and connections.
7. If trusses have been designed for timber fascias, do not replace with steel fascia without asking your truss supplier to check the overhang design.

## Transport

Trusses must be fully supported when being transported in either a horizontal or vertical plane. Care must be taken when tying down, not to put strain on chords or webs.

Timber or metal right angle protectors are a satisfactory method of avoiding damage. Unloading and handling is described opposite.

## Job Storage and Lifting

Trusses should be inspected on arrival at site. Any damaged trusses should be reported immediately and not site repaired without approval of the truss fabricator.

Where it is anticipated that trusses will be stored on site for an extended period of time before use, adequate provision should be made to protect trusses against the effects of weather.

Once trusses are installed they should not be left exposed to weather for long periods. Repeated wetting and drying has a detrimental effect on the strength of both timber and connection.

Protective covering, where used, should allow free air circulation around trusses.

Trusses when stored on the job site should be on timber fillets clear off the ground and in a flat position to avoid distortion.

When lifting, care must be taken to avoid damaging of joints and timber. Spreader bars with attachment to the panel points should be used where span exceeds 9000 mm. Never lift by the apex joint only.

The trusses may also be placed on the top plates by pulling them up on skids, spread at 3000 mm, taking the same precaution as described above.

Ensure that the trusses are not distorted or allowed to sag between supports.

The recommended method of lifting trusses will depend on a number of factors, including truss length and shape.

In general, sling truss from top chord panel points as shown below. Slings should be located at equal distance from truss centreline and be approximately  $\frac{1}{3}$  to  $\frac{1}{2}$  truss length apart.

The angle between sling legs should be  $60^\circ$  or less and where truss spans are greater than 9000 mm a spreader bar or strongback should be used. Some typical examples are shown below.

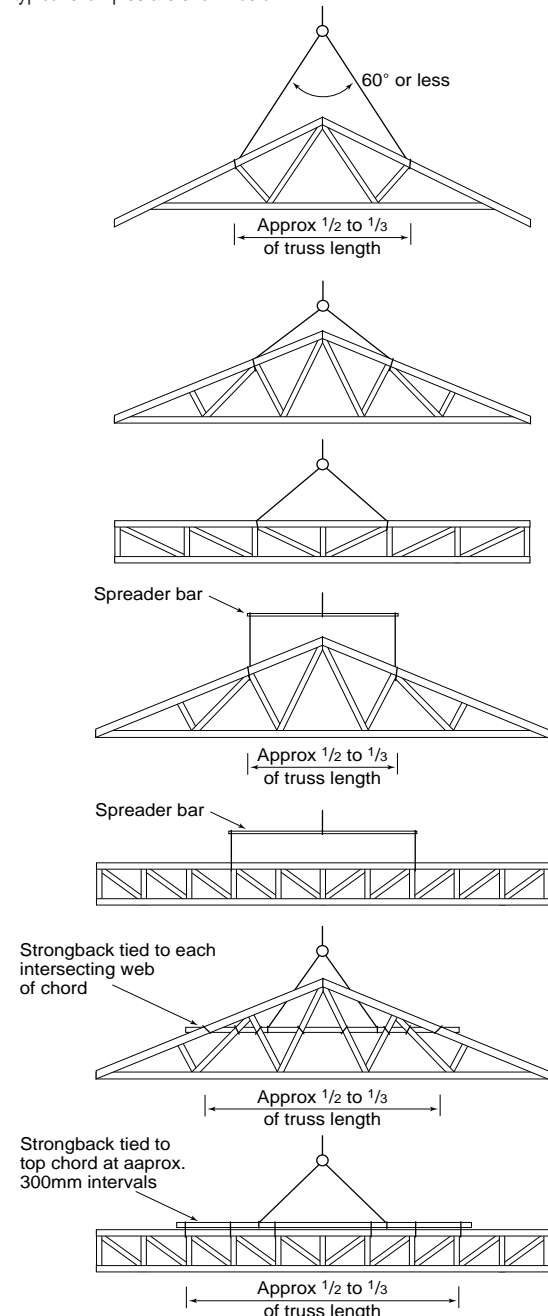

# Roof Layout

A layout for trusses must be determined before erection. If in doubt consult your truss fabricator.

Points circled on these layouts may be critical. Refer to the Wall Frame Construction Notes.

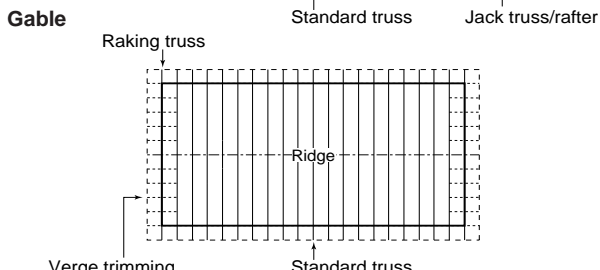
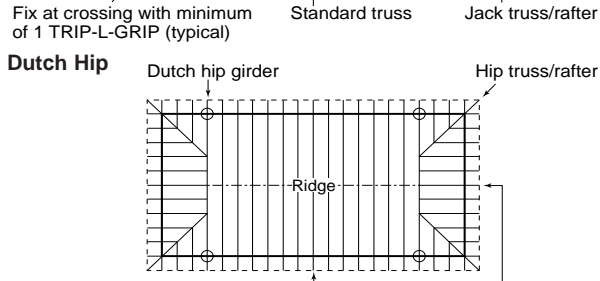
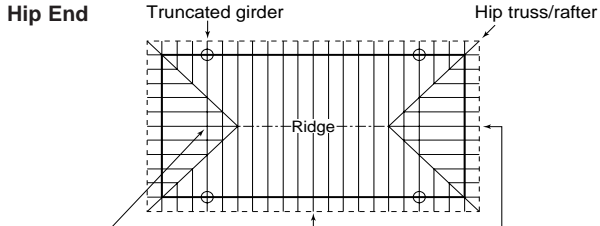

NOTE: End gable truss to be located over end wall unless otherwise advised by supplier.

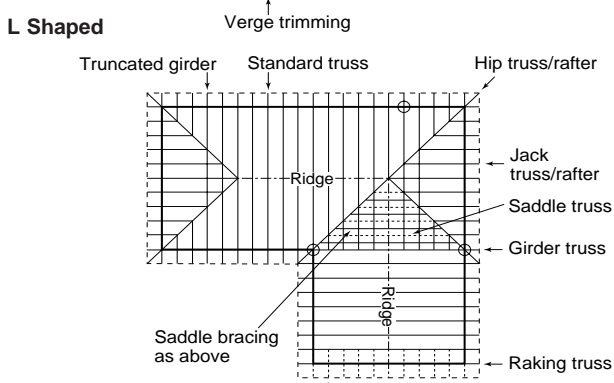
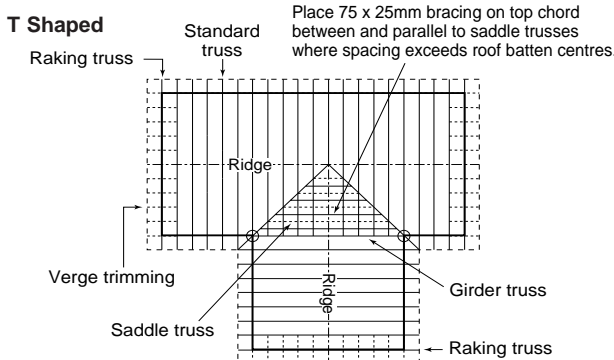

**Gable Ends**  
Where a gable end is required, consult your truss fabricator for details of construction and erection.

## Supporting Structure (Frame or Brick)

A structure that is not level and is out of square will result in an ugly and unsatisfactory roof line. Time is well spent in ensuring:

1. The load bearing top plates are level.
2. The structure is of the correct dimension.
3. The top plates as well as being level, are straight in their length.
4. The internal walls are set below the outer wall level by:  
Unbattened ceiling – 10 mm.  
Battened ceiling – 10 mm plus batten thickness.

Note: For 900 mm spaced trusses, plasterers prefer to use 50 mm battens.

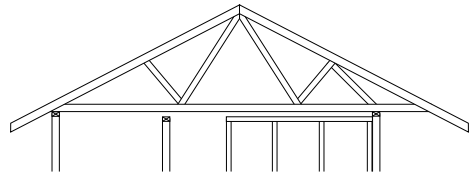

## Wall Frame Construction

The load bearing frames should be checked for:

1. Lintel sizes suitable for truss loading. Consult AS1684 or your truss fabricator.
2. If trusses are not located directly over studs the top plate size must be in accordance with AS1684.
3. Girder trusses may require the strengthening of studs at the points of support. Check the loading with your truss fabricator and refer to AS1684. Points circled on the layout notes are critical.

The supporting structure construction must be adequate to resist wind up-lift forces.

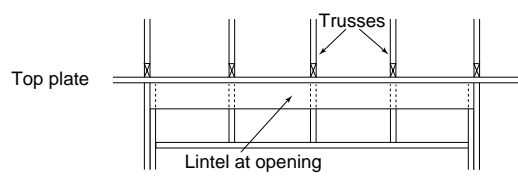
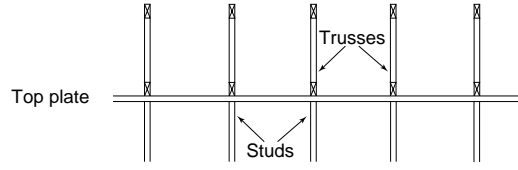

**Top plate strengthening may be required where trusses do not coincide with studs.**

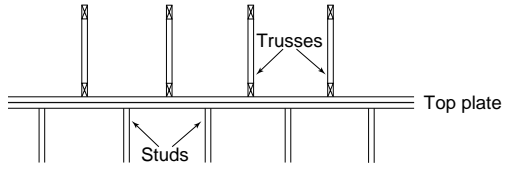

## Frame Bracing

The frame must be fully braced, plumb, and nailed home before the erection of trusses is commenced.

## Erection and Fixing

It is convenient to mark the truss position on the wall plates before lifting trusses. Use the layout drawing as your guide and note that the truss design spacing must not be exceeded.

Ensure first truss is installed carefully and within erection tolerances.

**WARNING** – Do not use web as ladder to climb up or down the roof during installation. This can cause damage to the web and lead to serious injury.

**Gable Roofs** – start with a gable truss at each end, fixing it to the top plate at the position marked. These trusses must be temporarily braced back to the ground or frame at the panel points.

**Hip or Dutch Gable** – start with the Dutch girder truss or the truncated girder, placing it on the top plate at the position marked and temporarily bracing it back to the frame. Locate hip and jack trusses and adjust girder truss position before fixing.

**Line** – Using a stringline along the Apex, place each intermediate truss and fix it to the top plate at the position marked, spacing it with gauging rods and ties.

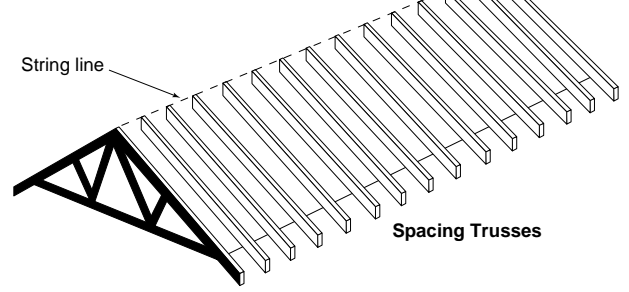

## Camber

Trusses are built with a camber in the bottom chord. The camber is designed to suit the span and load. A girder truss will have more camber than other trusses. The camber is progressively taken up as the load from the roof covering and ceiling is applied. Under no circumstances should trusses be supported along the span (unless designed for) by blocking or propping.

If a truss has been designed to be supported internally a "SUPPORT HERE" label is affixed to the appropriate point.

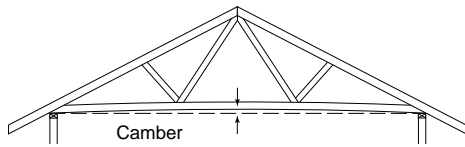

## Erection Bracing

The trusses must be braced during erection. If this is not done, then two problems can occur.

1. Collapse during erection
2. Erection tolerance will be exceeded, causing overloading, buckling and possible permanent damage.

The exact details of erection bracing will, for practical purposes, differ from job to job. The following recommendations are for guidance only as the details employed are the erectors responsibility.

The first truss should be erected straight and plumb to erection tolerances given previously and temporarily braced to a rigid element, e.g. wall or ground as shown on diagram following.

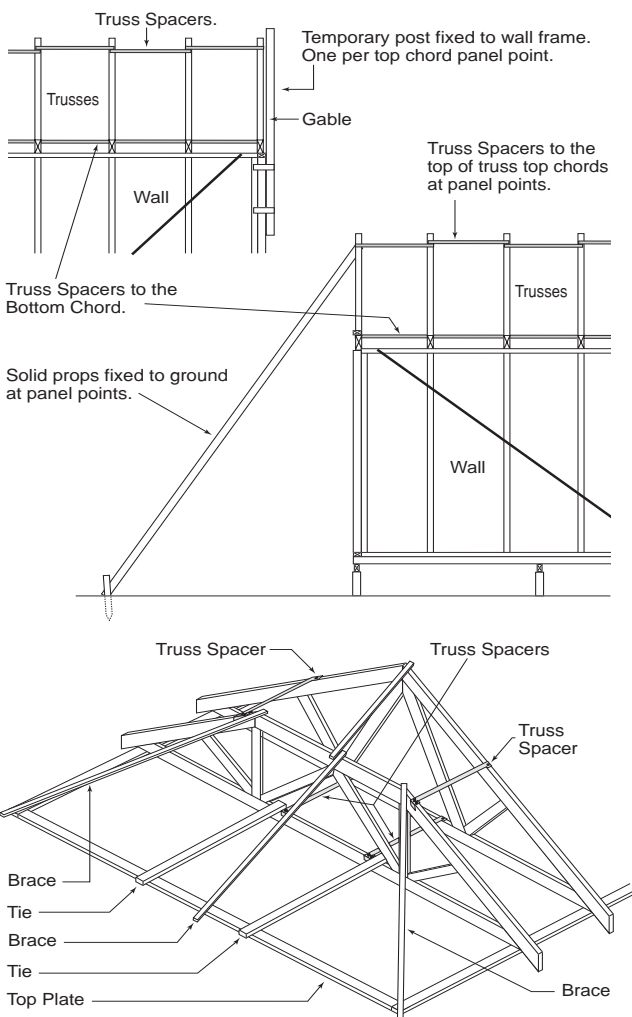

Each successive truss should be spaced using Truss Spacers. Truss Spacers are recommended in lieu of gauging rod or timber ties, as these can be fixed to the trusses prior to lifting trusses on to top plates.

**Do not stand on a truss that does not have all its Truss Spacers or temporary ties fixed.**

The purpose of temporary bracing is to hold trusses straight and plumb prior to fixing permanent bracing, ties, hold down, etc. must be fixed prior to loading roof.

**Code requirements** - Australian Standard for the installation of nailplated trusses AS4440-2004 requires that temporary ties are to be used on top chords at spacings no greater than 3000 mm and on bottom chords at spacings no greater than 4000 mm. However, it is good practice to place top chord ties at each top chord panel point.

The Truss Spacer is designed to replace the temporary chord ties as required by AS4440. To conform with AS4440-2004 requirements use Truss Spacers as below.

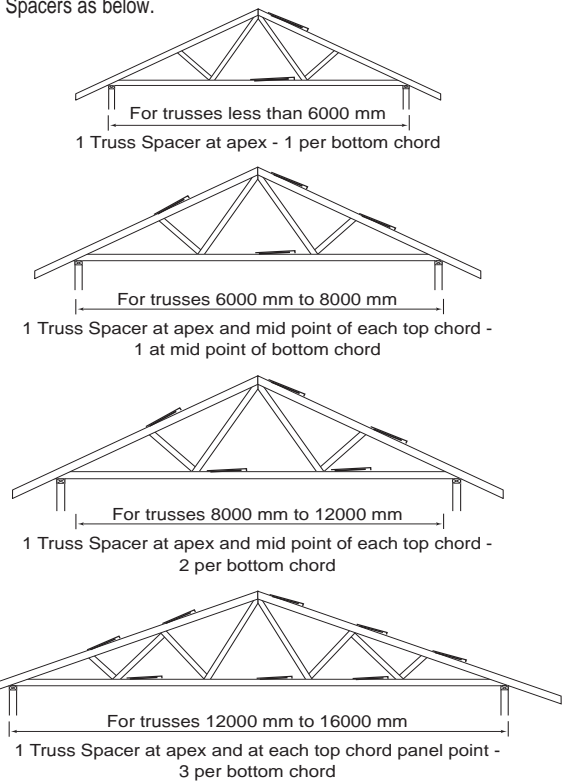

**See Truss Spacer Installation Instructions for further information.**

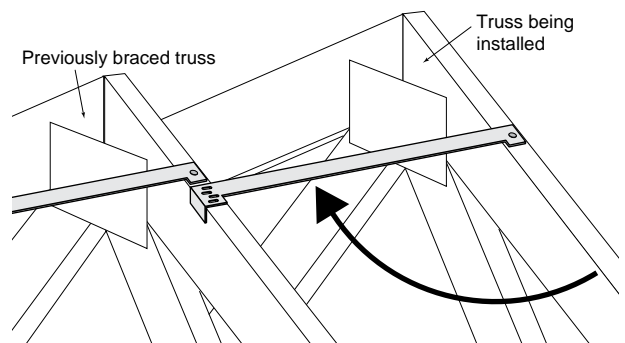

## Important Note

These recommendations are a guide only for the erection of standard gable trusses up to 13000 mm span, and spaced at centres not exceeding 1200 mm. For trusses beyond these conditions, consult your truss fabricator.

## Erection Tolerances

Tolerance is critical for both a good roof line and effective bracing. A stringline, a plumb line or level should be used.

1. Trusses to be erected with minimal bow, in the truss and in any chord, with a tolerance not exceeding the lesser of  $L/200$  and 50 mm, where  $L$  is as defined as shown in diagrams.
2. Trusses to be erected so that no part of the truss is out of plumb with a tolerance exceeding the lesser of height/50 and 50 mm.

Generally if a bow or tilt is evident to the eye, the truss has been erected outside the tolerances.

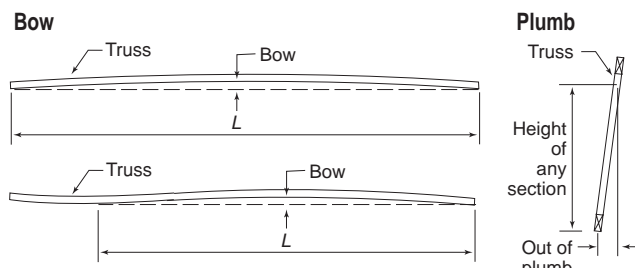

# Fixing to Top Plate

## INTERNAL OR NON-LOAD BEARING WALLS.

### (a) Non-Bracing Wall

If internal or non-load bearing walls are not designed as bracing walls, fix the truss with the INTERNAL WALL BRACKET with nails at the top of the slot to allow for truss settlement as it is loaded. Brackets are fixed at 1.8 m centres along unsupported sections of the wall. Where trusses are parallel to walls, trim between the bottom chords and fix brackets to the trimmer. Where non-load-bearing walls are stable in their own right, no Internal Wall Brackets are required.

#### Trusses parallel to non-bracing wall

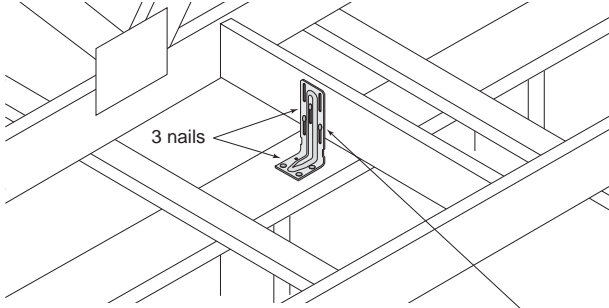

#### Trusses at right angle to non-bracing wall

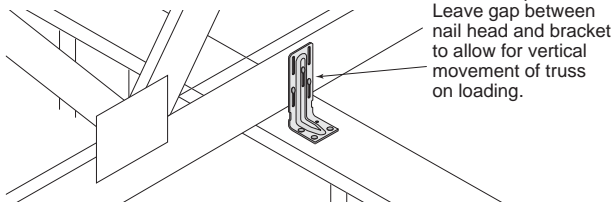

### (b) Bracing Wall

Where internal walls are non-load bearing but are designed as bracing walls, trusses should be fixed to the top plate using structural connections of equivalent strength to the bracing strength of that particular bracing wall. The connection should also allow the truss to deflect vertically when it is loaded.

#### Trusses at right angles to bracing wall

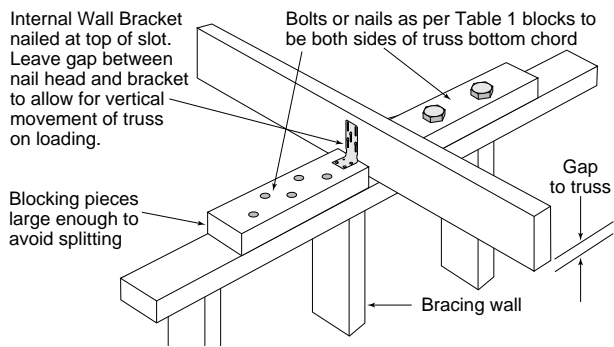

#### Trusses parallel to bracing wall

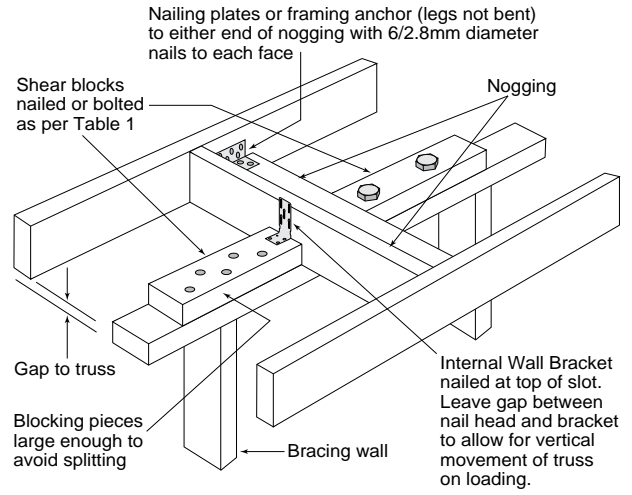

### (c) Non-Load Bearing External Wall

For non-loadbearing external walls, such as verandah walls where trusses are pitched off verandah beams or other beams, the top plate of the wall should be stabilized at maximum 3000 mm centres as shown.

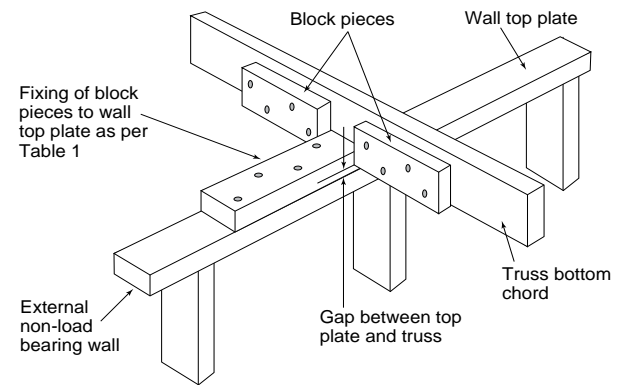

## EXTERNAL OR LOAD BEARING WALLS.

Each end of the truss should be fixed to the top plate in accordance with Table 4 on page 13.

## Fixing to Girder Trusses

Special Girder Brackets are available for supporting standard trusses on the bottom chords of Girder Trusses. These brackets should be fully fixed in accordance with details supplied by the truss fabricator prior to loading roof. (Refer page 14).

## Fixing of Valley (saddle) Trusses

Connection of valley (saddle) trusses to be in accordance with details supplied by the truss fabricator or those in AS4440-2004.

## Fixing of Multiple Ply Trusses

Multiple ply trusses are required to be joined in accordance with the following recommendations to comply with design assumptions.

Table 1 - Fixing details for Bracing Walls

N - Not Suitable

Type of Connection	Number of Type A or Type B bracing units in braced wall (Refer AS1684 Part 4)											
	Unseasoned Timber						Seasoned Timber					
	J2		J3		J4		JD4		JD5		JD6	
	Type A	Type B	Type A	Type B	Type A	Type B	Type A	Type B	Type A	Type B	Type A	Type B
<b>Nails</b>												
4/3.05ø	1.6	N	1.1	N	N	N	1.1	N	N	N	N	N
6/3.05ø	2.1	1.1	1.5	N	1.1	N	1.6	N	1.2	N	1.0	N
4/3.33ø	1.9	N	1.3	N	N	N	1.3	N	1.1	N	N	N
6/3.33ø	2.4	1.2	1.7	N	1.2	N	1.8	N	1.5	N	1.1	N
<b>Bolt Size</b>												
M10	2.5	1.3	2.2	1.1	1.7	N	2.0	1.0	1.6	N	1.3	N
M12	3.3	1.6	2.6	1.3	2.1	1.0	2.4	1.2	1.9	1.0	1.5	N
<b>Screws</b>												
2 No.14 Type 17	3.2	1.6	2.3	1.2	1.6	N	2.3	1.2	1.6	N	1.2	N
3 No.14 Type 17	5	2.5	3.3	1.7	2.5	1.2	3.3	1.7	2.5	1.2	1.8	N

**Example:** Determine fixing of top of bracing wall which has 1 Type A bracing unit. The joint strength group of the wall framing and the braced wall is JD4.

From table 1, the connection of 4/3.05ø nails has a fixing capacity of 1.1 number of Type A bracing wall for JD4 joint strength group. Therefore, fix 4/3.05ø nails to shear blocks at both sides of truss bottom chord.

## STANDARD, TRUNCATED AND HIP TRUSSES

### Double Truss (nail one side only)

Join all chords and webs with nails or screws staggered one side only. \*Nails or screws to be at 300mm centres for top chords and 450mm centres for bottom chord webs.

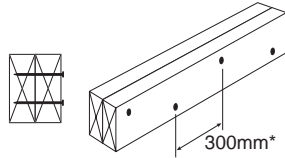

### Triple Truss (nail both sides with bolts at panel points)

Join outer trusses to centre truss using the double truss details. In addition, join trusses at each panel point with one M12 bolt.

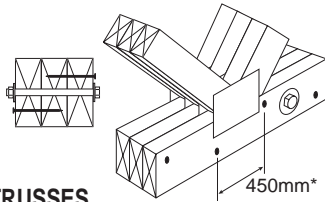

## GIRDER AND DUTCH HIP TRUSSES

Nail as for standard trusses except maximum nail or screw centres to be 300mm to all chords and webs. Waling Plates to be fixed to each chord and web with bolts or screws in accordance with DTRS-0015 or MIRS-0008. Where Press-On Girder Brackets are used, join bottom chord with one M12 bolt or 2 screws located within 100mm of each Girder Bracket.

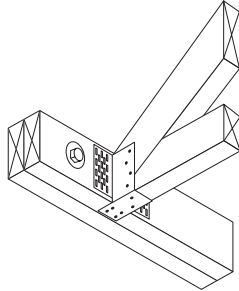

### Nailing Details (all truss types)

For 35mm thick trusses use 3.75mm diameter deformed shank nails\* or 14 gauge x 65mm long screws.

For 45mm thick trusses use 4.5mm diameter deformed shank nails\* or 14 gauge x 75mm long screws.

Use 50 x 50 x 3.0mm square washers or 55 dia. x 3.0mm round washers with M12 bolt.

For further information refer to DTRS-0020.

\*Machine-driven nails can be used to connect multiple ply trusses provided they are glue coated or deformed shank nails. The minimum diameters of machine-driven nails are to be 3.05mm for hardwood and cypress, and 3.33mm for softwood timbers.

## Hip End Fixing

The following details recommend the minimum requirements for fixing hip ends. These recommendations are suitable for use with trusses up to 900 mm maximum spacing supporting tiles roof and 1200 mm maximum spacing supporting sheet roof. Maximum truncated girder station is 3600 mm.

### Notes:

1. These connections are adequate, based on general domestic construction practices which include at least two 2.5 mm skew nails, with a penetration of 10 times of nail diameter to supporting member, connecting each member.
2. Nails details may be substituted by screws with equivalent capacity.
3. These details are also applicable for use in conjunction with conventional hip ends.

### For Wind Classification N1, N2, N3 or C1

Connection of trusses at hip end for wind classification N1, N2, N3 or C1 are in accordance with the details shown and described in Figure 1 and Detail A1 to E1.

Figure 1. Typical trussed hip end connection for Wind Classification N1, N2, N3 or C1

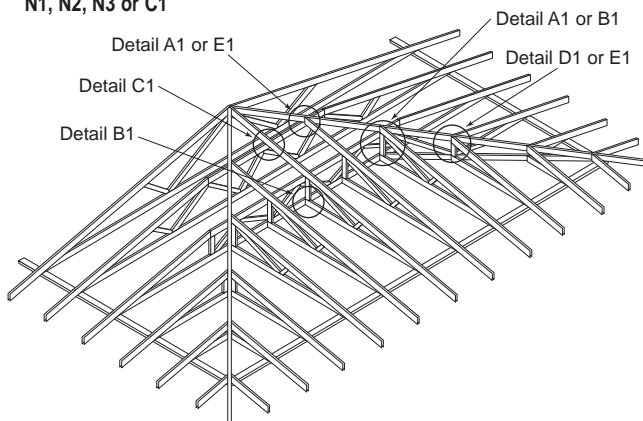

### Notes:

1. For effective skew nailing, the nail shall be driven into one member not closer than 25 mm to no more than 38 mm from the arris in contact with the adjacent member. The nail shall be driven at an angle between 30° and 45° to the face into which the nail is driven.
2. Where nails are smaller than the nominated size or other than plain shank nails, or machine driven, or both, their performance shall not be inferior to the nail size given.
3. Roof battens or purlins and ceiling battens shall be fixed to trusses in accordance with approved specifications.

### Detail A1 - Hip Truss to Truncated Girder Truss

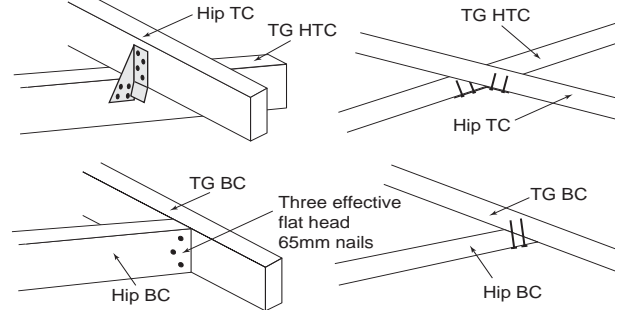

### Detail B1 - Jack Truss to Truncated Girder Truss

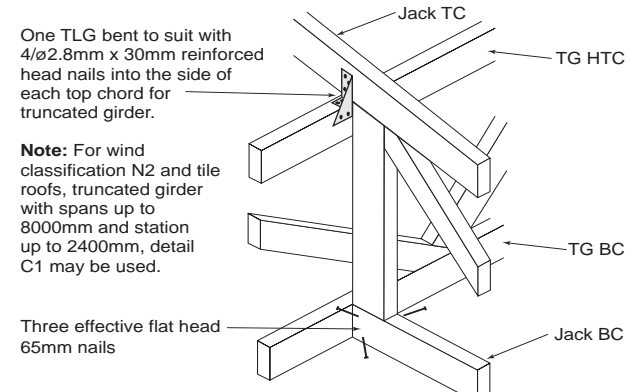

### Detail C1 - Extended Jack or Hip Truss to top chord of Truncated Standard Trusses

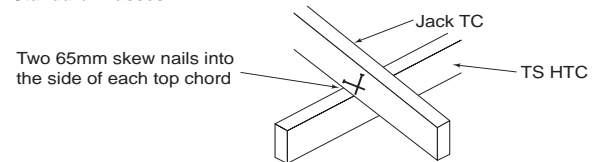

### Detail D1 - Jack Truss to Hip Truss (maximum jack station 1800 mm)

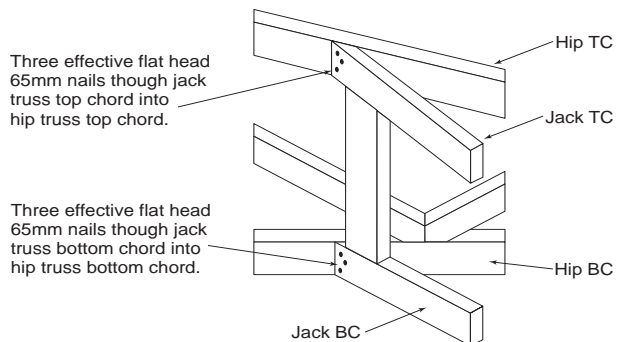

### Detail E1 - Jack Truss to Hip Truss (maximum jack station 3000 mm)

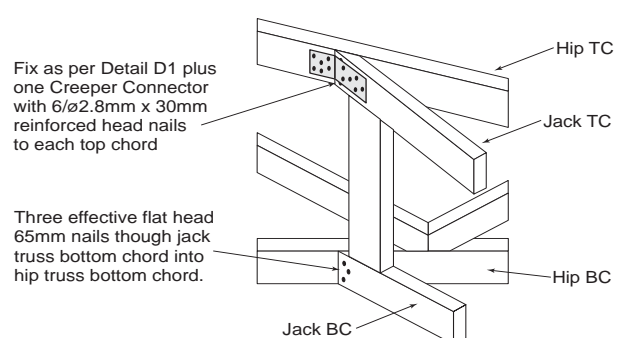

## For Wind Classification N4, C2 or C3

Connection of trusses at hip end for wind classification N4, C2 or C3 are in accordance with the details shown and described in Figure 1 and Detail A2 to E2.

**Figure 2. Typical trussed hip end connection for Wind Classification N4, C2 or C3**

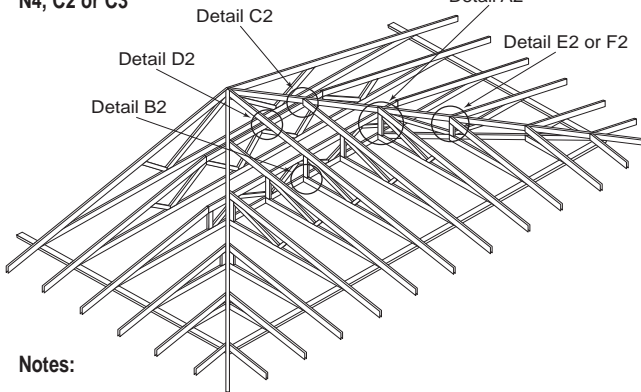

### Notes:

1. For effective skew nailing, the nail shall be driven into one member not closer than 25 mm to no more than 38 mm from the arris in contact with the adjacent member. The nail shall be driven at an angle between 30° and 45° to the face into which the nail is driven.
2. Where nails are smaller than the nominated size or other than plain shank nails, or machine driven, or both, their performance shall not be inferior to the nail size given.
3. Roof battens or purlins and ceiling battens shall be fixed to trusses in accordance with approved specifications.
4. Jack trusses are assumed to be supported in the horizontal top chord of the truncated girder.

### Detail A2 - Hip Truss to Truncated Girder Truss

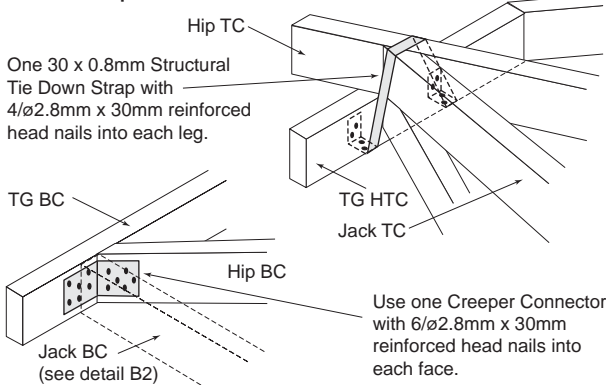

### Detail B2 - Jack Truss to Truncated Girder Truss

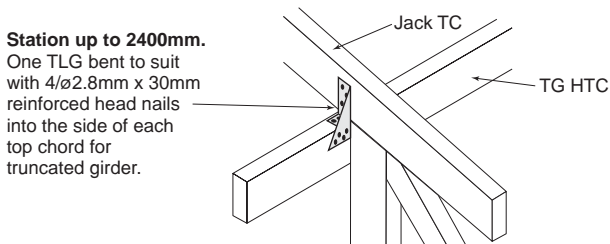

### Detail B2 - Jack Truss to Truncated Girder Truss cont.

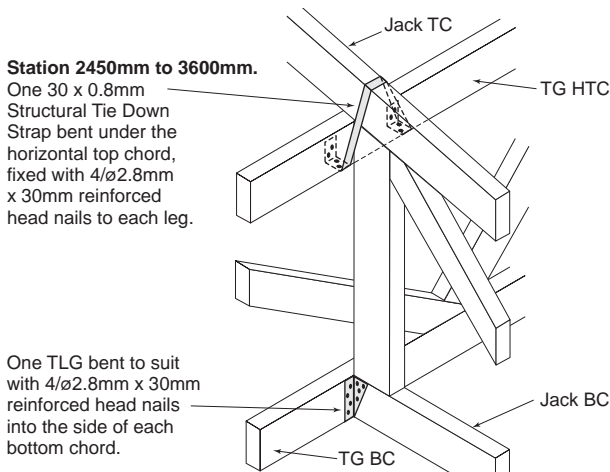

### Detail C2 - Intersection of Jack and Hip Truss to Truncated Standard Truss

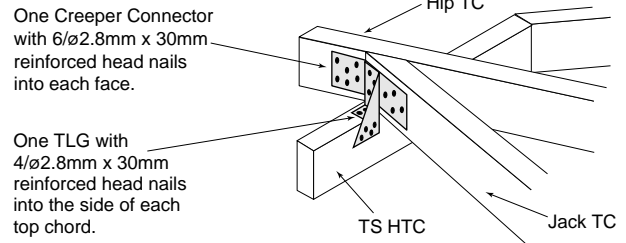

### Detail D2 - Extended Jack or Hip Truss to top chord of Truncated Standard Trusses

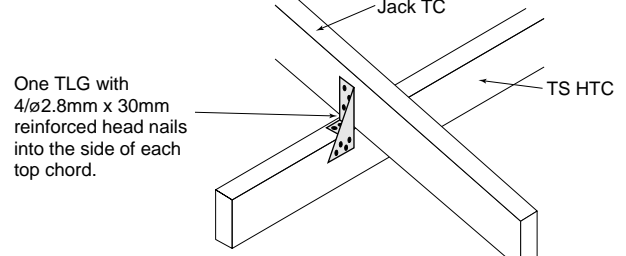

### Detail E2 - Jack Truss to Hip Truss (maximum jack station 2400mm)

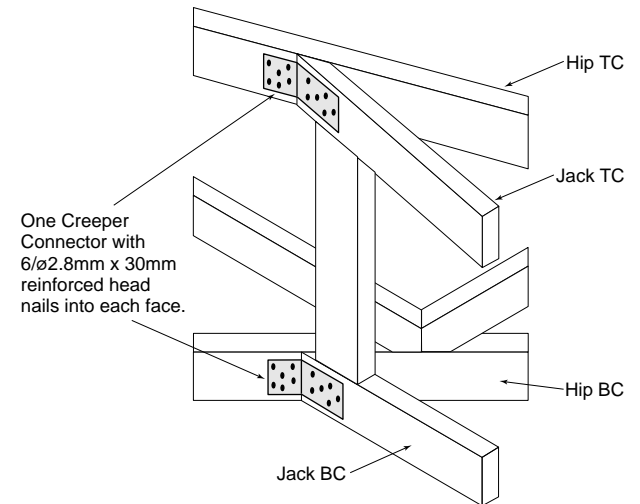

### Detail F2 - Jack Truss to Hip Truss (maximum jack station 3000mm)

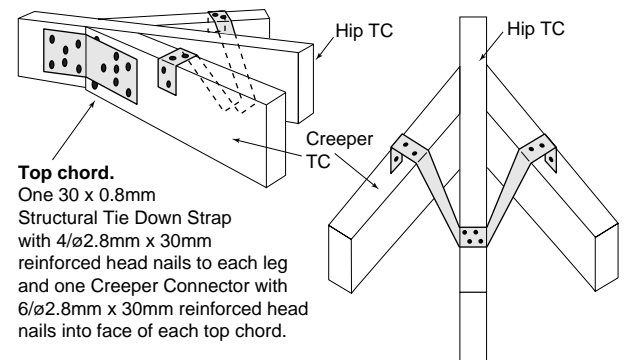

**Bottom Chord.** See detail E2

### Creeper Connectors

Creeper connectors have been designed to connect jack trusses to hip trusses. They may be used wherever a mitre plate is specified in AS4440-1997.

#### CC200 Creeper Connector (ø = 90°)

Suitable for low pitch roofs or for bottom chord connection. That is, pitches 0° to 12.5° pitched chords.

#### CC200R and CC200L Creeper Connectors (ø = 70°)

Suitable for pitches from 13° to 30° and that suffix L and R defines that the product is designed for left hand or right hand connection.

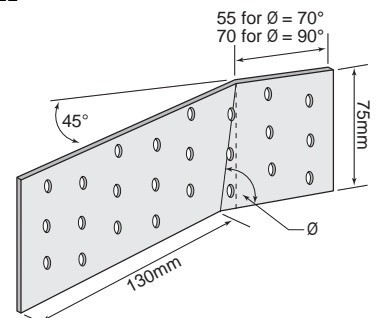

# Roofing Battens

The stability of any roof system is reliant on the tile or sheeting battens. The contract with the roofer should include the following provisions:

Roofing battens should be fixed securely to all truss top chords in accordance with AS1684 unless otherwise specified by local building regulations. For multiple ply trusses, battens should be fixed securely to each ply of truss top chord with at least one nail or other mechanical fixing. Battens wider than 50mm should be secured with two fixings to each ply.

Battens to be arranged so that on any truss top chord, not more than 1 in 3 battens are spliced and no two splices are adjacent.

In the areas of roof not bounded on both sides by diagonal bracing, battens should be continuous, if not use "Batten Strapnails" to splice.

Roof should not be loaded until all roofing battens are securely fixed.

**WARNING: Some types of steel tile battens do not provide adequate lateral restraint to truss top chords. Before using steel tile battens obtain certification from your steel batten supplier confirming that their product will provide at least the same lateral restraint as timber battens.**

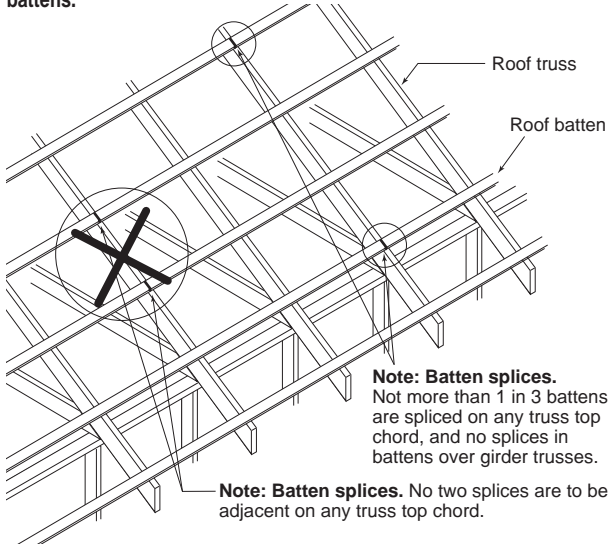

## Splice details for roof battens supporting sheet roof

The splice details have been designed to resist axial loads on battens transmitted by truss top chord under the following criteria:

- Standard trusses supporting sheet roof at 1200mm crs and 16000mm span maximum.
- Maximum batten spacing = 1200mm
- Batten size and grade to be in accordance with AS1684 span tables.

Batten splices should be typically located away from girder trusses. Use detail with stiffener as shown in Option 4.

**Tie Downs** - Batten to truss fixing should be checked for adequacy against tie-down requirement.

### OPTION 1

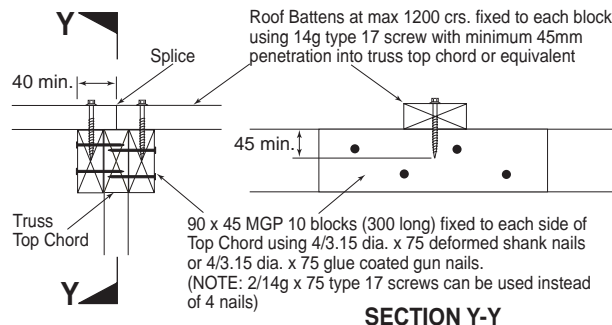

### OPTION 2

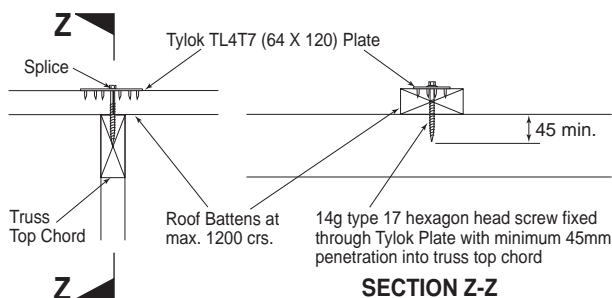

### OPTION 3

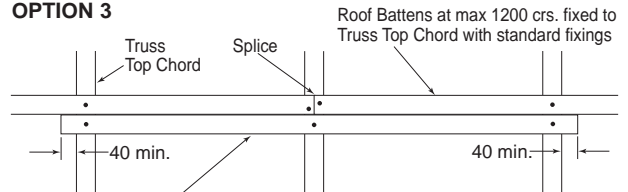

Bridging Batten same size and grade as the batten fixed to Truss Top Chord using 1/14g type 17 screw with minimum 45mm penetration into truss top chord or equivalent

### OPTION 4

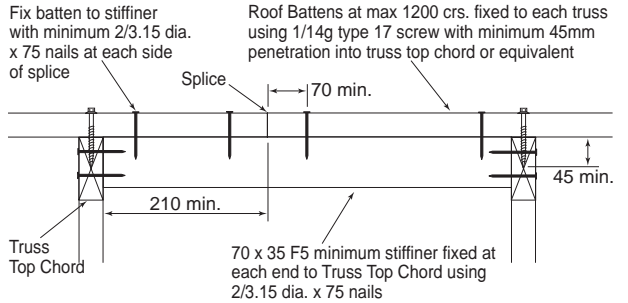

### OPTION 5

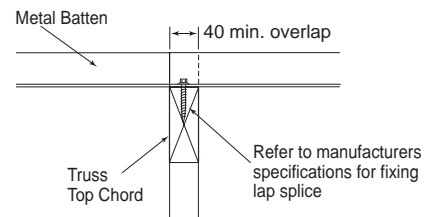

## Permanent Bracing

Before loading, roof trusses must be permanently braced back to the rigid building element, such as support walls, to prevent rotation or buckling of trusses under the weight of roof and ceiling material or under wind uplift.

These recommendations provide for:

- Wind Classifications for areas up to C3 (W60C).
- Walls being stable and braced in their own right.
- Roof spans up to 16000 mm.
- Maximum truss centres:
  - 900 mm in Wind Classification areas up to C3 (W60C).
  - 1200 mm for sheet roofs in Wind Classification areas up to N3 (W41N).
- Maximum roof pitch of 45°.

**For conditions beyond these, consult your truss manufacturer.**

## SPEEDBRACE

Speedbrace is a bracing system for the bracing of trussed roofs in both low wind speed and cyclone areas.

Speedbrace is manufactured in accordance to AS4440-1997's steelbrace specification.

Speedbrace is a tension bracing system that uses a pre-punched shallow 'V' shaped member that is easily handled and erected. Speedbrace is applied in an 'X' or 'V' pattern to the top of the chord and braces the trusses back to the frame.

Speedbrace offers many advantages over other bracing systems.

- Applied to top of top chord – speed and simplicity.
- Pre-tension – no turnbuckles or similar device is required to tension the brace.
- Maximum load is governed by end fixing and splicing which are to be made strictly in accordance with details shown in this publication.
- Pre-punched – nailing made quick and easy with special 30 x 2.8 galvanized reinforced head nails.
- Uniform strength – assured performance.
- Side by side splicing for easy layout and fixing.
- Positive end fixing – wrap around at apex, splice and frame.

(Clouts should not be used in fixing Speedbrace.)

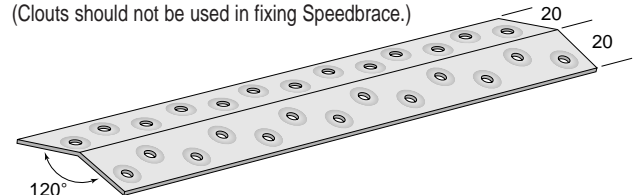

## Bottom Chord Bracing

When plasterboard ceilings are fixed direct to the bottom chords of trusses or via battens in accordance with AS1684, the horizontal wind load on the roof and walls of a house is normally transferred to the bracing walls through the diaphragm action of the plasterboard ceiling. This structural ceiling diaphragm also provides lateral restraint to the truss bottom chords of the trusses.

If there is no ceiling attached to the bottom chord, or if the ceiling is suspended or fixed using furring channels that are clipped to the bottom chord, then an alternative bottom chord bracing system is required to provide truss stability and building stability.

Where plasterboard is not fixed direct or via battens then:

1. Truss stability is achieved by using bottom chord binders and diagonal bracing on the bottom chord similar to roof bracing. The bottom chord binders should be spaced in accordance with the truss design. The ends of both bottom chord binders and diagonal bracing are to be anchored to a rigid building element.
2. A structural engineer should be consulted for specific design of a bottom chord bracing system which is suitable for the particular requirements of the building.

## Top Chord Bracing

The bracing layout is related to the span and shape of the roof.

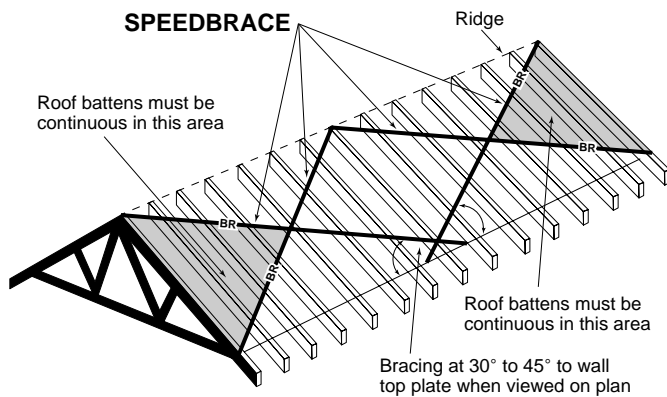

## Roof spans less than 8000 mm

The forces in a roof of less than 8000 mm span are relatively low and may be restrained by the use of a single Speedbrace in a "V" configuration. The angle of Speedbrace to wall frame should be between 30° and 45°, and each truss should be crossed with at least two braces.

For roof lengths less than half span (h) use detail for Very Short Roofs below.

1. **Very Short Roof** – where the roof length "L" is 1 to 1½ times the half span "h" of the roof truss.

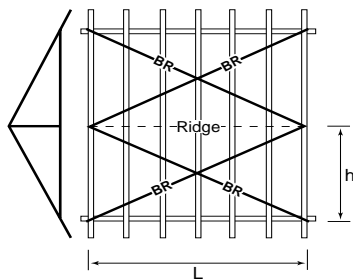

2. **Short Roof** – where the roof length "L" is 1½ to 3½ times the half span "h" of the roof truss.

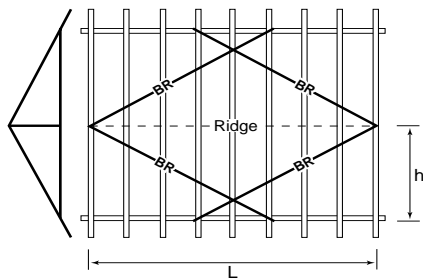

### LEGEND:

TRUSS/ SUPPORT	
BRACING	
RIDGE	

3. **Long Roof** – where the roof length "L" is 3½ to 4 times the half span "h" of the roof truss.

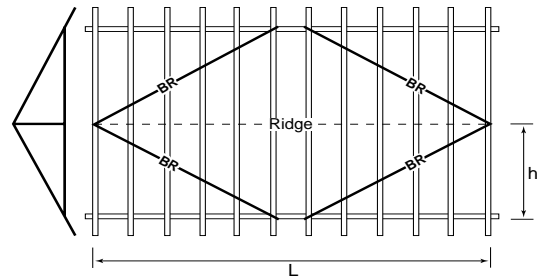

4. **Very Long Roof** – where the roof length "L" is more than 4 times the half span "h" of the roof truss.

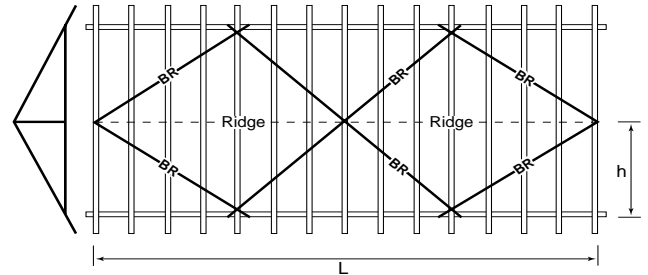

## Roof Spans 8000 mm to 13000 mm

The increase in span increases the forces to be restrained requiring the use of Speedbrace in an "X" configuration. The angle of the Speedbrace to the frame should be between 30° and 45°. Use a single Speedbrace with maximum overall truss length not exceeding values in Table 2.

Table 2 - Maximum truss span (m)  
for single Speedbrace of roof spans 8 m to 13 m

Roof pitch	Wind Classification		
	N3 (W41N), C1 (W41C)	N4 (W50N), C2 (W50C)	C3 (W60C)
< 15°	13.0	13.0	12.0
15° to 20°	13.0	13.0	11.0
21° to 30°	12.5	10.5	8.5
31° to 35°	11.5	9.5	Not Suitable
36° to 45°	9.5	8.0	Not Suitable

Each truss should be crossed with at least four braces and bracing bays should extend from the end trusses of the building unless noted otherwise.

1. **Very Short Roofs.** Where the roof length "L" is very short compared to the half span "h" of the roof trusses and would result in a brace angle greater than 45°, a diagonal bracing arrangement is required each side of the ridge line as given below. Bracing bays should be spaced across roof such that the brace angle is always between 30° and 45°.

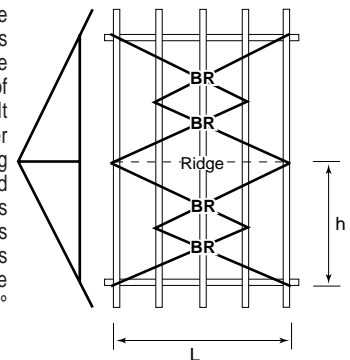

2. **Short Roofs.** Where the roof length "L" is of length to give a brace angle between 30° and 45° then only one bay of bracing is required each side of the ridge line as shown.

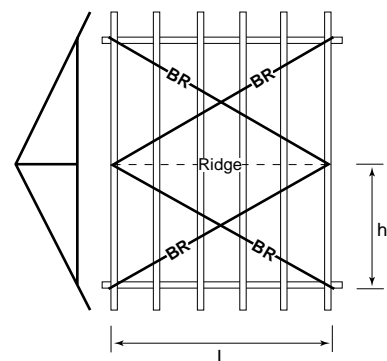

3. **Long Roofs.** Where the roof length "L" is long compared to the half span "h" of the roof trusses and would result in a brace angle less than 30°, two or more crossed bracing bays are required each side of the ridge to ensure the brace angle is between 30° and 45° as shown.

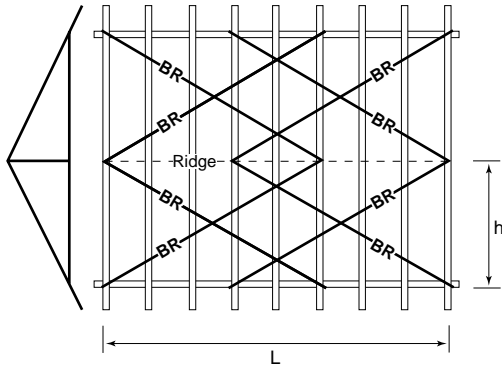

4. **Very Long Roofs.** As for long roofs, except continue bracing for length of building such that each truss is crossed with at least four braces.

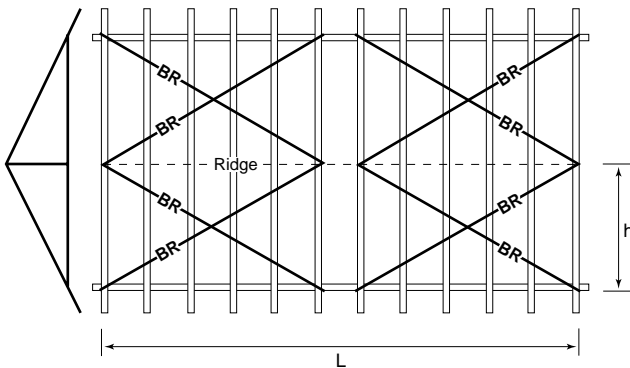

For a roof with overall truss span greater than the maximum values specified in Table 2, but less than 13.0 m, use a double Speedbrace as shown below.

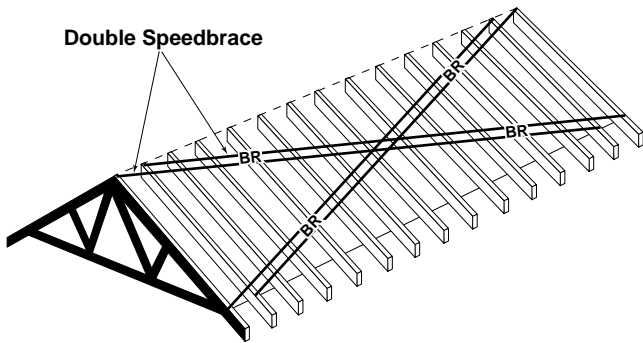

### Roof Spans 13000 mm to 16000 mm

a) For standard trusses, refer to Table 3 to determine whether single or double Speedbrace can be used in an 'X' configuration over the whole roof with an additional braced bay at each end as shown.

**Table 3 - Maximum truss span (m)**  
for single and double Speedbrace of roof spans 13 m to 16 m

Roof pitch	Wind Classification		
	N3 (W41N), C1 (W41C)	N4 (W50N), C2 (W50C)	C3 (W60C)
Single Brace			
< 15°	16.0	15.5	Not Suitable
15° to 20°	16.0	13.0	Not Suitable
Double Brace			
< 15°	16.0	16.0	16.0
15° to 20°	16.0	16.0	15.5
21° to 30°	16.0	14.5	Not Suitable
31° to 35°	16.0	13.5	Not Suitable
36° to 45°	13.5	Not Suitable	Not Suitable

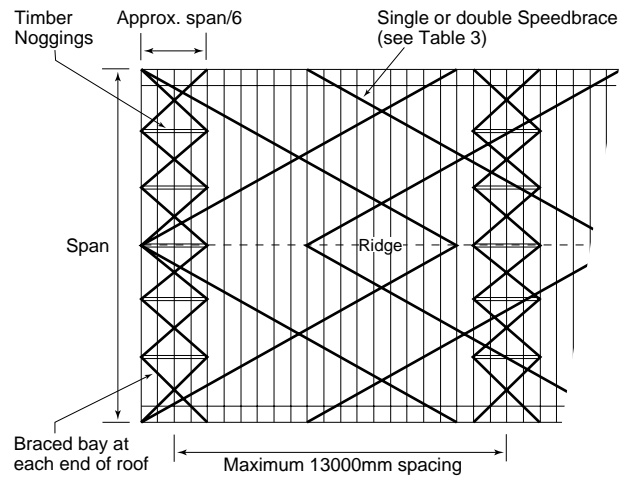

b) For jack trusses or rafters, use single Speedbrace in an 'X' configuration and the angle of Speedbrace to end wall should be between 30° and 45°.

1. Where the horizontal top chord length (HTL) is less than the truncated girder station (TGS).

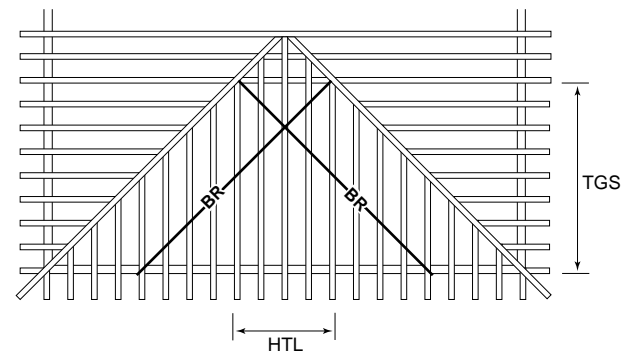

2. Where the horizontal top chord length (HTL) is 1 to 1.5 times the truncated girder station (TGS).

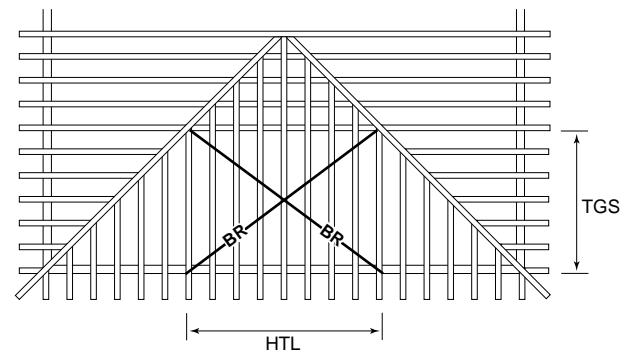

3. Where the horizontal top chord length (HTL) is longer than 1.5 times the truncated girder station (TGS).

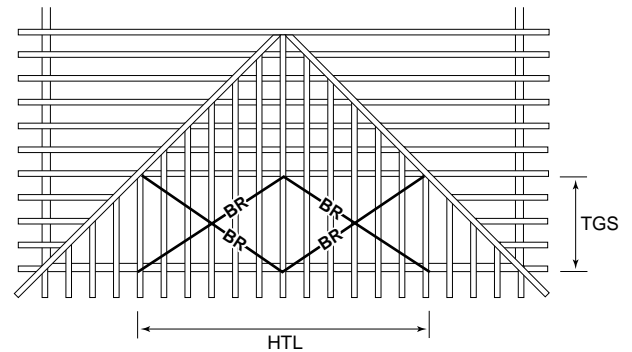

### Typical Bracing Layouts

#### Gable Roof

Select a roof layout such that the angle between the ridge line and the brace is between 30° and 45°. There are eight basic bracing arrangements to consider depending on truss span and building length as given above. Bracing bays should extend from end trusses on the building.

## Hip Roof

For roofs on buildings of rectangular plan with trussed hip ends or dutch hip ends, bracing is required between apex of hip ends only. In such cases the roof length "L" is taken as being the distance between the intersection of hip and ridge lines at each end of the building and either of the above gable recommendations adopted.

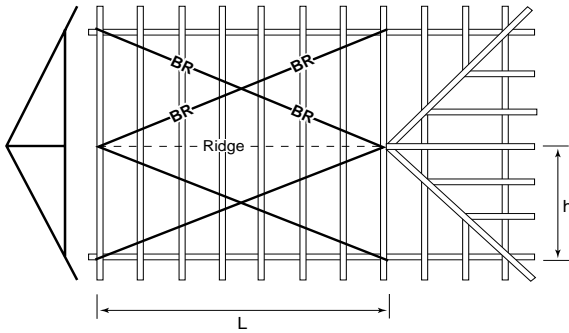

## Dual Pitched

On dual pitched roofs and cut-off roofs where the ridge line is not central on the building it may be necessary to determine bracing layout from a combination of 1, 2, 3 and 4 above. In such cases each side of the ridge shall be considered as a separate case.

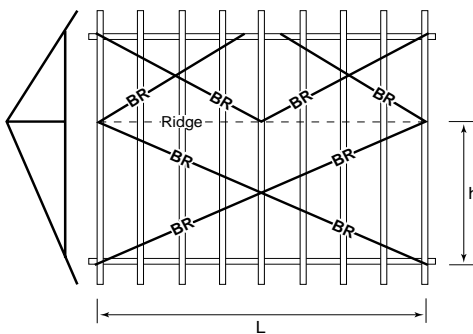

## Bell Roof

Bell trusses should be braced as shown. The Speedbrace should be spliced at bell breaks.

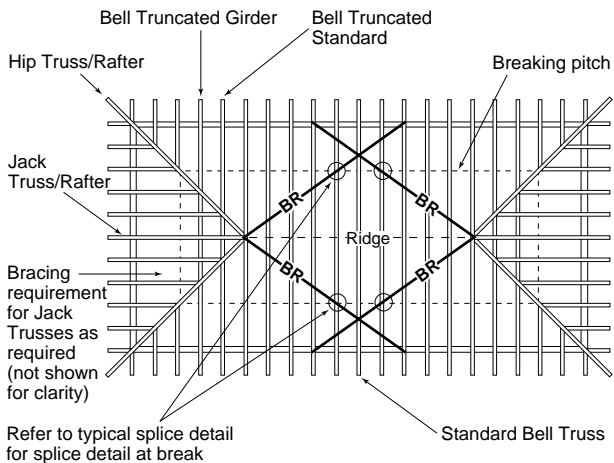

## Skillion

Where the roof consists of half trusses, the span of the half truss should be taken as the half span "h" when using the above recommendations, and the apex braced to supporting structure. See section on Treatment of Internal Supports etc.

### NOTE:

The previous are typical layouts for bracing. However, for special circumstances, e.g. small spans and complex roof shapes, bracing layout will be supplied.

## Speedbrace Fixing Details

1. Always use 30 mm long x 2.8 mm dia. Galvanized Reinforced Head Nails when fixing Speedbrace.
2. At each truss, fix Speedbrace to the top of the top chord with two nails. Select nail holes most central to the timber edge. Flatten bracing while nailing to avoid interference with battens.
3. At end truss fix off the Speedbrace as shown. A pair of tinsnips will cut the brace. After fixing to top of top chord use your hammer to form a tight bend and fix to face of top chord with three nails.

## Typical End Fixing Details

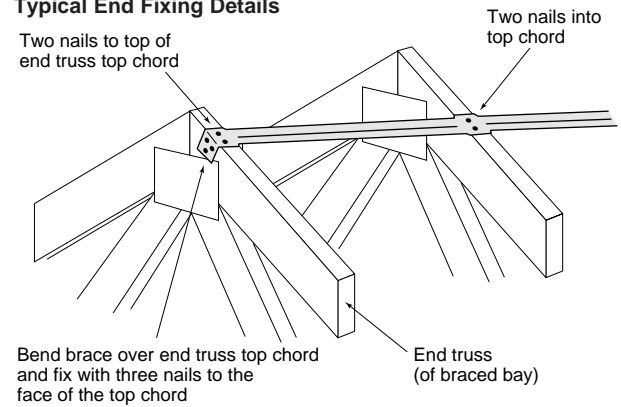

4. To splice Speedbrace, overlap or wrap around over one truss and fix with three nails. Splice to be located at least 3500 mm from heel end fixing, measured along brace.

### Typical Splice Detail (Overlap Splice)

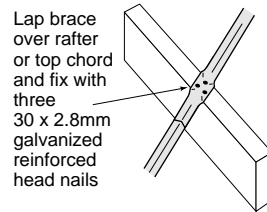

### Typical Splice Detail (Wrap-around Splice)

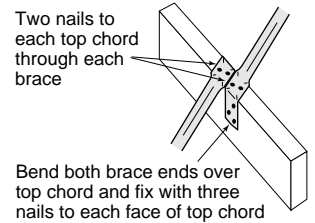

5. At the heel, Speedbrace should be fixed in one of the following ways:-

The simplest method, where roof geometry permits is to fix directly to the wall top plate as shown below. The brace must be kept straight between the last braced truss and wall top plate. Also the angle between the brace and the wall top plate must not exceed 45°, i.e. 1:1 slope.

## Heel End Fixing Details

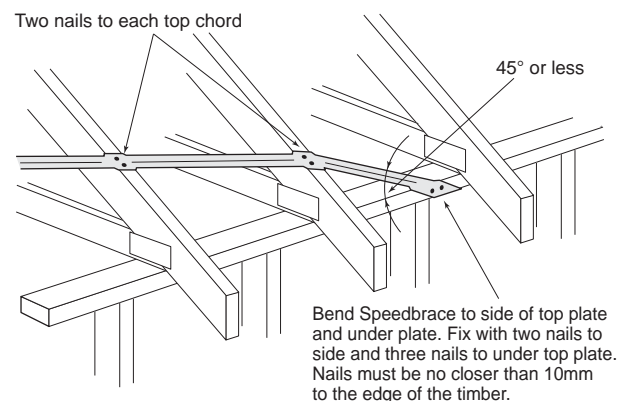

### CAUTION

The Speedbrace must be positively fixed to the top plate otherwise the bracing will be ineffective.

An alternative method can be used where it is desired to extend the brace to the last truss or where the angles do not permit ready fixing to the top plate. The last two trusses should be fixed to the wall top plate with a minimum of two Trip-L-Grips to each truss, and timber block between trusses as shown.

## Alternative Heel End Fixing Detail

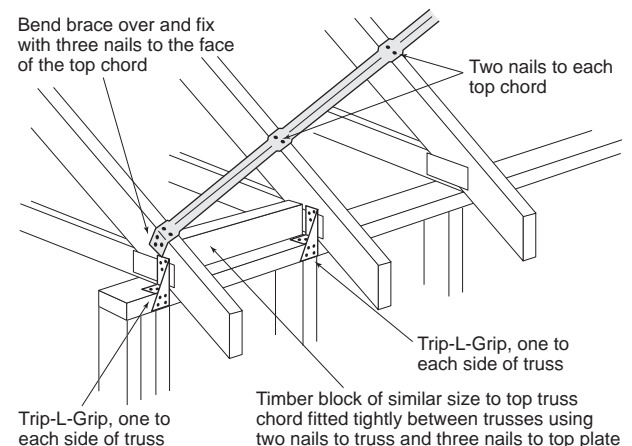

Where the standard trusses are supported by a girder truss or a beam rather than a wall top plate, fix Speedbrace at truss heel as shown following.

### Heel End Fixing at Girder or Beam

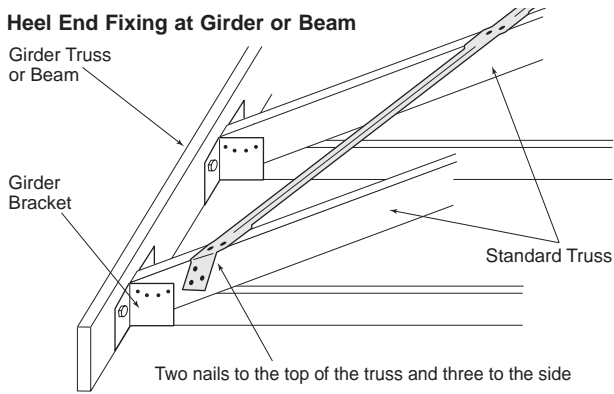

### Treatment at Cantilevers

The force in the top chord bracing must be carried through to the wall plate by diagonal bracing from the top chord to wall plate, as shown below.

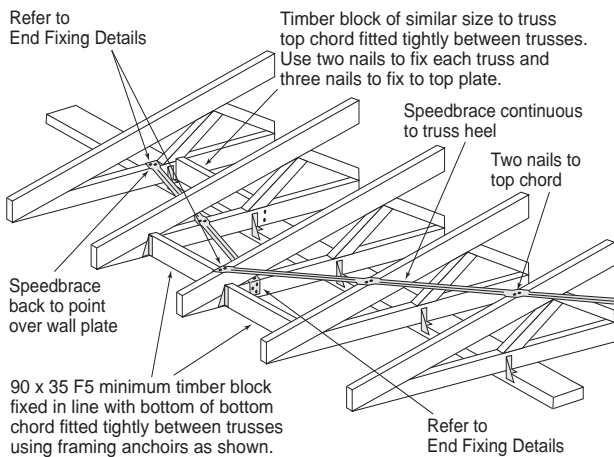

### Treatment at Cut-off or Half trusses

In addition to top chord bracing, cut-off and half trusses require bracing from top chord to top plate at end nearest apex. Apply one bay of diagonal bracing at each end of the run of trusses and intermediate bays at 10m centres for long runs of trusses.

#### End Bracing for Cut-off and Half Trusses

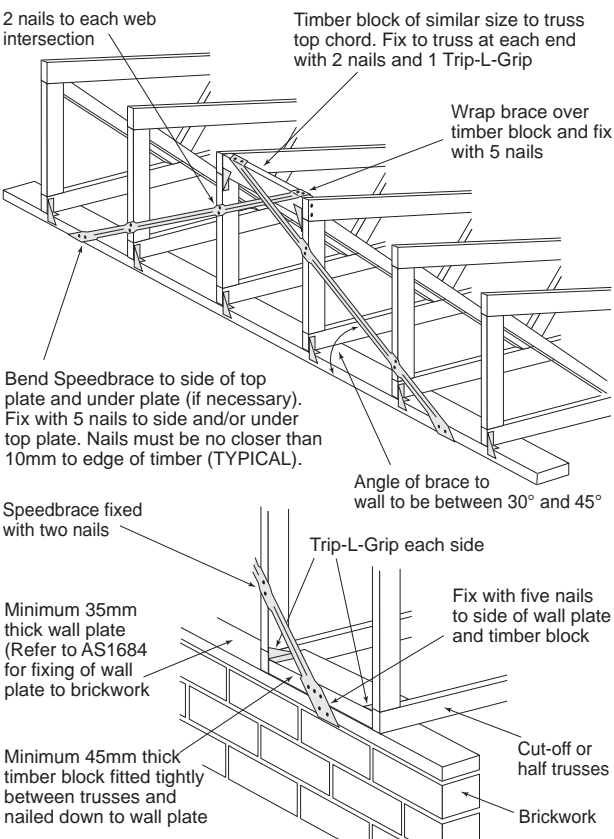

### Web Ties & Stiffeners

Some truss designs require longitudinal ties, stiffeners or other supplementary members to be applied to webs. Where longitudinal ties are used, they should be 70 x 35 (F5) or as specified by the truss fabricator. Where longitudinal ties are used, they should be continuous and fixed to web of each truss at mid-height with 2 x 3.75 dia. nails and braced back to truss with one bay of crossed Speedbrace at each end and intermediate bay at 10m centres fixed as shown below. Ties may be spliced by lapping over 2 adjacent trusses.

Web stiffeners may be specified in lieu of web ties where it is difficult to fit web ties because of the small number of trusses or the varying position of the webs. eg. Truncated trusses and Hip trusses.

Web stiffeners may be timber sections fitted on-site or steel Eliminator stiffeners fixed during manufacture. Where timber stiffeners are used these should be the size and grade specified by the truss designer and should be continuous for the full length of the web. Timber stiffeners are to be fixed as below.

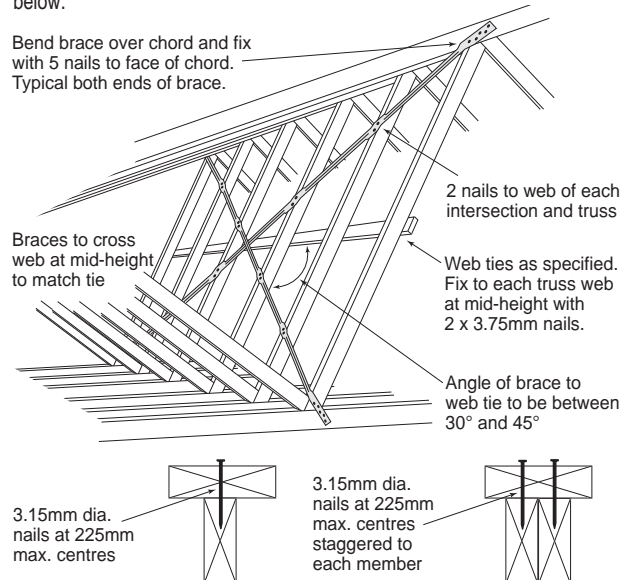

### Truss Spacer for Web Tie

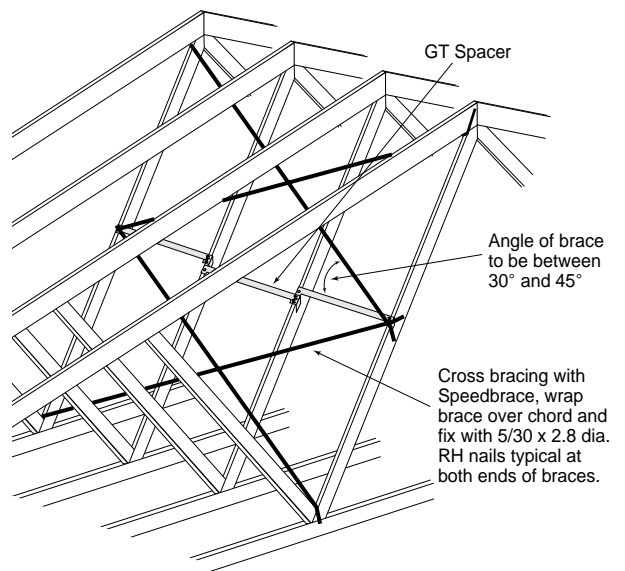

The Truss Spacer can also be used as permanent lateral bracing for webs in standard roof trusses for domestic constructions. The Truss Spacer can be used as a web tie where truss designs require bracing to be applied to webs for the following conditions.

Roof materials:	Sheet or tile roof
Ceiling material:	13mm plasterboard, battened
Spacing:	600 and 900mm
Pitch:	45° max.
Span:	16m
Wind Classification:	Up to C2

# Hold-Down Details For Trusses – Cyclonic & Non-Cyclonic

Fixing types for roof load width, spacings and roof covering are given in Table 4.

Uplift Load Width (ULW) is used to determine the tie-down fixing type for standard trusses only and calculated as follows:

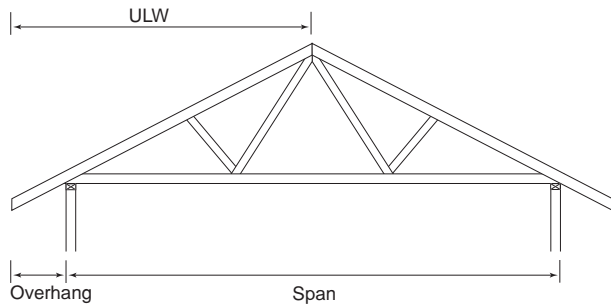

$$ULW = \frac{SPAN}{2} + OVERHANG$$

## DESIGN DATA

The Uplift Load Widths (ULW) in Table 4 have been designed for the following criteria:

**Roof materials:** Steel sheet with 13 mm plasterboard ceiling fixed with battens, or concrete tile with 13 mm plasterboard fixed direct to truss bottom chord.

Overhang: 600mm

Maximum pitch: 25°

Min. joint group for calculating hold down: JD4

Wind Load:

Wind Classification	Maximum Design Gust Wind Speed (m/s)		Pressure coefficient	
	Permissible stress method ( $V_p$ )	Ultimate limit state ( $V_u$ )	External ( $C_{pe}$ )	Internal ( $C_{pi}$ )
N2	33 (W33N)	40	-0.9	0.2
N3	41 (W41N)	50	-0.9	0.2
C1	41 (W41C)	50	-0.9	0.7
C2	50 (W50C)	61	-0.9	0.7
C3	60 (W60C)	74	-0.9	0.7

Pressure coefficients used are for the extreme case. Reductions may be achieved depending on building type, dimensions, room layout, etc.

For a more accurate assessment of hold down requirements on specific jobs, refer to truss design outputs.

The details should be used as a guide only as hold down requirements will vary depending on the type of supporting structure. The method of hold down is the responsibility of the builder.

Details for fixing wall plates to foundations are to be provided by others. The supporting structure must also be designed by others to resist all vertical and horizontal loadings.

Table 4

Fixing type	Maximum Uplift Load Width (ULW), mm			
	Sheet		Tile	
	Spacing (mm)			
	900	1200	600	900
<b>Wind Classification N2</b>				
2/3.75 dia. x 75 mm skew nails	900	700	2600	1600
1 TrussGrip	2100	1600	5900	3600
2 TrussGrips	4300	3200	10600	7300
1 Trip-L-Grip	5200	3800	10600	8800
2 Trip-L-Grips	10400	7600	10600	10600
1 Cyclone Tie CT400 or CT600 (face fixed with 4 nails)	10300	7500	10600	10600
1 Cyclone Tie CT600 (face fixed with 6 nails)	10600	10600	10600	10600
1 Cyclone Tie CT600 (wrap under top plate)	10600	10600	10600	10600
1 Cyclone Tie CT600 (fixed to GN Lintel)	10600	10600	10600	10600
<b>Wind Classification N3</b>				
2/3.75 dia. x 75 mm skew nails	NA	NA	1000	700
1 TrussGrip	1200	900	2400	1500
2 TrussGrips	2400	1800	4900	3100
1 Trip-L-Grip	2900	2100	5900	3800
2 Trip-L-Grips	5800	4300	10600	7600
1 Cyclone Tie CT400 or CT600 (face fixed with 4 nails)	5800	4300	10600	7500
1 Cyclone Tie CT600 (face fixed with 6 nails)	8800	6500	10600	10600
1 Cyclone Tie CT600 (wrap under top plate)	9700	7200	10600	10600
1 Cyclone Tie CT600 (fixed to GN Lintel)	10200	7500	10600	10600
<b>Wind Classification C1</b>				
1 Trip-L-Grip	1800	1400	3400	2200
2 Trip-L-Grips	3700	2800	6800	4400
1 Cyclone Tie CT400 or CT600 (face fixed with 4 nails)	3700	2700	6700	4300
1 Cyclone Tie CT600 (face fixed with 6 nails)	5600	4200	10200	6600
1 Cyclone Tie CT600 (wrap under top plate)	6200	4600	10600	7300
1 Cyclone Tie CT600 (fixed to GN Lintel)	6500	4900	10600	7700
2 Cyclone Ties CT600 (wrap under top plate)	10600	9300	10600	10600
<b>Wind Classification C2</b>				
1 Trip-L-Grip	1200	900	2000	1300
2 Trip-L-Grips	2400	1800	4000	2600
1 Cyclone Tie CT400 or CT600 (face fixed with 4 nails)	2400	1700	4000	2600
1 Cyclone Tie CT600 (face fixed with 6 nails)	3600	2700	6100	4000
1 Cyclone Tie CT600 (wrap under top plate)	4000	3000	6700	4400
1 Cyclone Tie CT600 (fixed to GN Lintel)	4200	3100	7000	4600
2 Cyclone Ties CT600 (wrap under top plate)	8000	6000	10600	8900
<b>Wind Classification C3</b>				
1 Trip-L-Grip	800	600	1200	800
2 Trip-L-Grips	1600	1200	2500	1700
1 Cyclone Tie CT400 or CT600 (face fixed with 4 nails)	1500	1100	2600	1600
1 Cyclone Tie CT600 (face fixed with 6 nails)	2400	1800	3800	2500
1 Cyclone Tie CT600 (wrap under top plate)	2600	1900	4200	2800
1 Cyclone Tie CT600 (fixed to GN Lintel)	2700	2000	4500	2900
2 Cyclone Ties CT600 (wrap under top plate)	5300	3900	8500	5600

### TRUSSGRIP

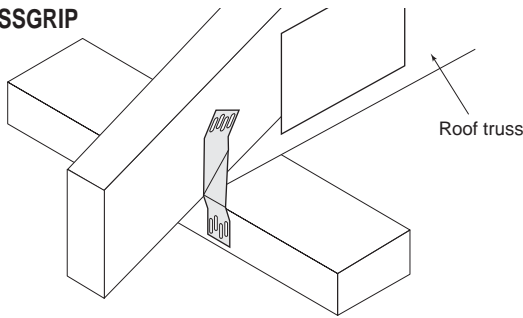

### TRIP-L-GRIP

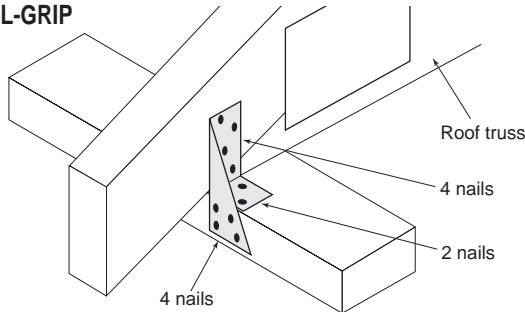

### TRIP-L-GRIP (fixed to GN Lintel)

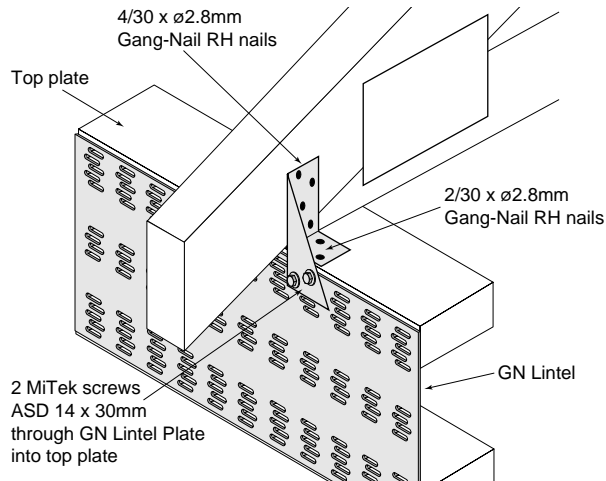

In cases where Trip-L-Grips will need to be fixed through the GN Lintel Plate, two MiTek screws ASD 14 x 30mm long may be used in place of 4 x 2.8 diameter nails into side of top plate to assist with the penetration of the GN Lintel Plate.

### CYCLONE TIE

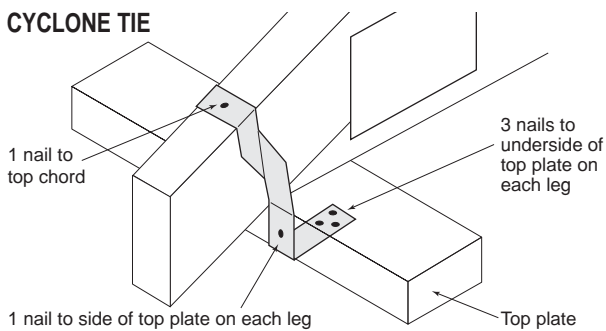

### CYCLONE TIE (face fixed to lintel)

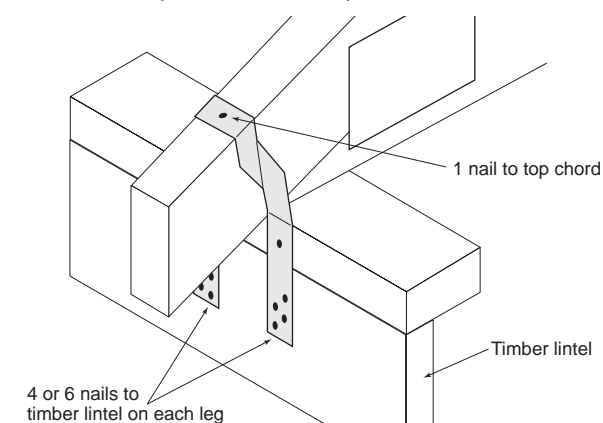

### CYCLONE TIE (face fixed to GN Lintel)

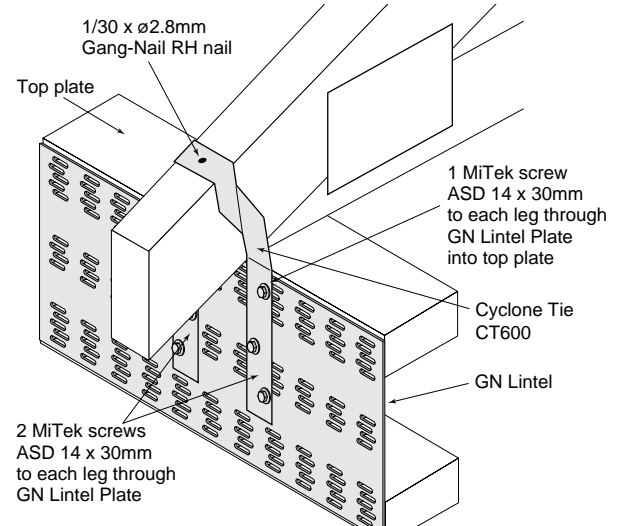

### 2 CYCLONE TIES

When using 2 Cyclone Ties (CT600), refer to Table 5 to ensure the tie is long enough to wrap under the top plate.

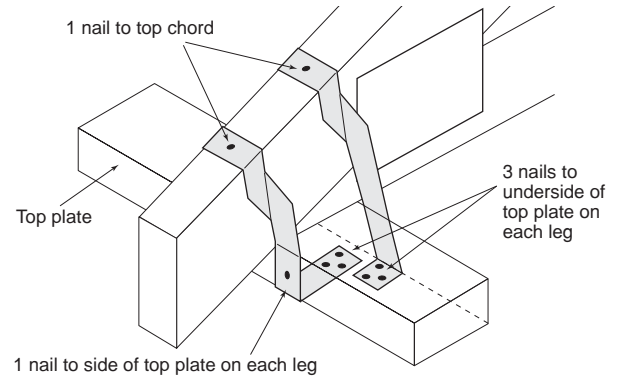

Table 5

Maximum Top Chord size	Top Plate size	Maximum Pitch (degree)
140 x 35	90 x 35	26.0
140 x 45	90 x 35	22.5
140 x 35	90 x 45	19.0
140 x 45	90 x 45	16.0
90 x 35	2 / 90 x 35	37.5
90 x 45	2 / 90 x 35	33.5
90 x 35	2 / 90 x 45	22.5
90 x 45	2 / 90 x 45	19.0

### Girder Brackets

Girder Brackets have been developed to support standard trusses on the bottom chord of girder trusses or beams, and may also be used to connect beams to beams. The brackets have been designed and tested to ensure that the load of the standard truss is transferred to the girder truss or beam without inducing rotation in the supporting member.

#### Determination of Bracket Type

A range of Girder Brackets are available. The type of bracket required for your project will depend on the loads which it is required to carry. The selection of bracket type should be done in conjunction with your MiTek fabricator or a Structural Engineer.

#### MKII Girder Bracket

MKII Girder Bracket has an integral tongue which prevents the rotation of the girder truss bottom chord when the trusses are loaded, and aids the location of the bracket during installation.

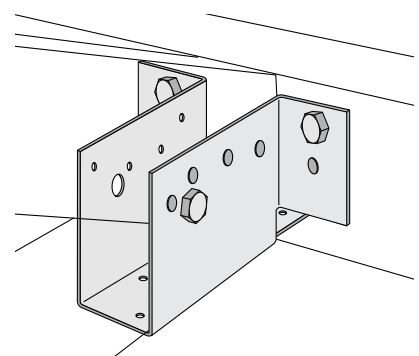

### Fast Fit MKIII Girder Bracket

Fast Fit MKIII Girder Bracket can be installed with either M12 bolts or MiTek self tapping screws for speedy installation.

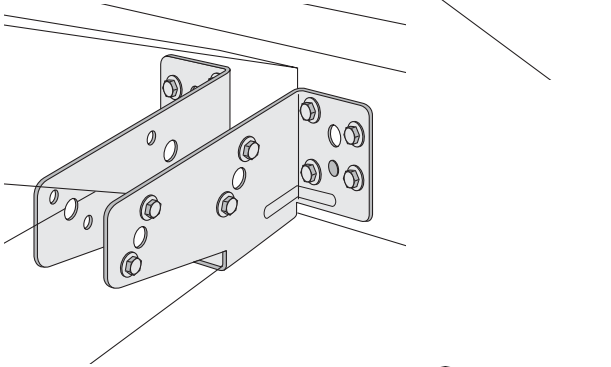
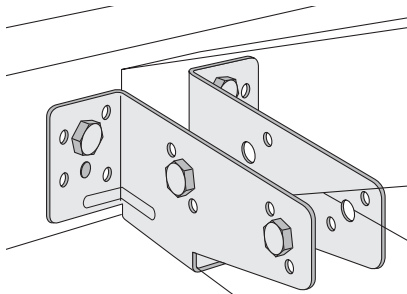

### Fast Fit MKIII Cyclonic Girder Bracket

Fast Fit MKIII Girder Bracket can be used in cyclonic wind areas to restrain large uplift if additional washers and screws are used as specified.

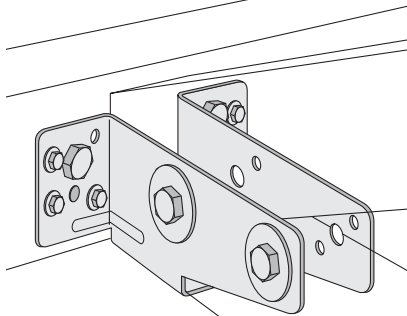

### Press On Girder Bracket

As the Press On Girder Bracket is fixed using integral teeth no bolts are required. The integral teeth also reduce the tendency of stress splitting of the supporting member.

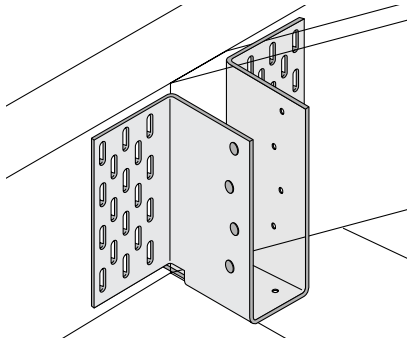

## GENERAL FIXING INSTRUCTIONS:

1. Install the Girder Truss straight and plumb. Apply temporary and/or permanent bracing as required by design.
2. Locate bracket on Girder Truss bottom chord and hold in position by nailing through locating holes. **Notes: Nailing is not required if using bracket with locator tab and screw fitting. When using bracket with anti-rotation tab, fix with 2 nails**
3. Where bolting is required, drill through the 12mm pre-punched holes into Girder Truss bottom chord. Fix bracket to Girder Truss bottom chord with bolts ensuring correct washers are used to provide bearing against the timber. Where screws are to be used, drive screws through pre-punched holes into Girder Truss bottom chord. For double ply girder trusses use 65mm long screws. For three ply girder trusses, use 100mm long type 17 self drilling screws, manufactured in accordance with AS3566, and adopt design capacity of the two ply girder truss.

**Joining multiple ply girder trusses:-** refer to page 6 for details.

Connect multiple ply trusses with nails or screws before fixing the Girder Bracket to avoid truss separation.

4. Position Standard Truss in the bracket so that it is hard against the face of the Girder Truss bottom chord.
5. Fix Standard Truss bottom chord to bracket as per specific fixing diagrams for particular Girder Bracket.
6. Ensure all bolts are tightened, screws and nails are fixed as soon as the supported truss is located correctly.
7. Proceed to install the other Standard Trusses.

### GENERAL NOTES apply to all Girder Bracket types:

1. Holes to be drilled to suit M12 bolts. Do not drill oversized holes. Use hexagonal head bolts. **DO NOT USE REDUCED SHANK OR CUP HEAD BOLTS.**
2. Use 50 x 50 x 3 mm square or 55 mm diameter x 3 mm round washer for M12 bolts.
3. Nails, where specified, to be 30 x 2.8mm diameter galvanised reinforced head nails.
4. Minimum Girder Truss bottom chords apply to each type of Girder Bracket. Refer Installation Instruction drawings.
5. Where ceiling is to be fixed directly to bottom chord, notching of the heel of supported trusses is recommended to obtain a better ceiling line, when using Press On, MKII and Fast Fit short tab Girder Brackets
6. Screws, where specified, to be MiTek Type 17 point hex head self drilling screws, with class 3 corrosion protection as per AS3566. **DO NOT OVERTIGHTEN SCREWS.** Use suitable power screw driver (not power drill) with torque clutch properly adjusted, or depth limiting driver.
7. When screws are to be driven through connector plates or into F17 or other dense timbers, pre-drilling or using 14g x 30 Type ASD screws to facilitate driving.
8. When driving screws into denser hardwood, screws should be driven in a single action. Do not partly drive screws and attempt to re-start. Remove partly driven screws and start process again.

### MKII

For sheet roof in Wind Classification N3, use additional M12 bolt. For higher Wind Classifications, refer to Engineer for details.

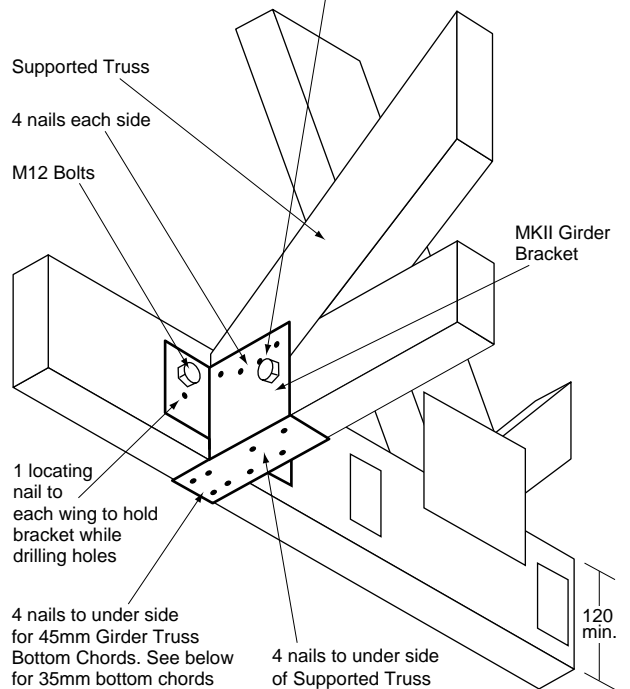

### Fixing Detail for 35mm Bottom Chords

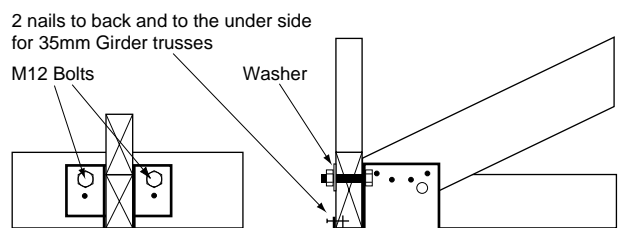

### Fast Fit MKIII - bolt fitting

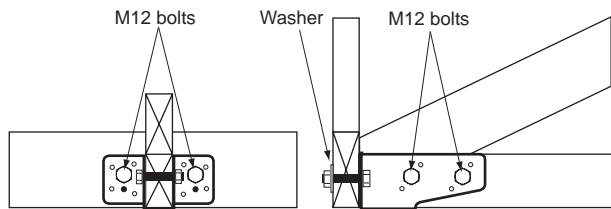
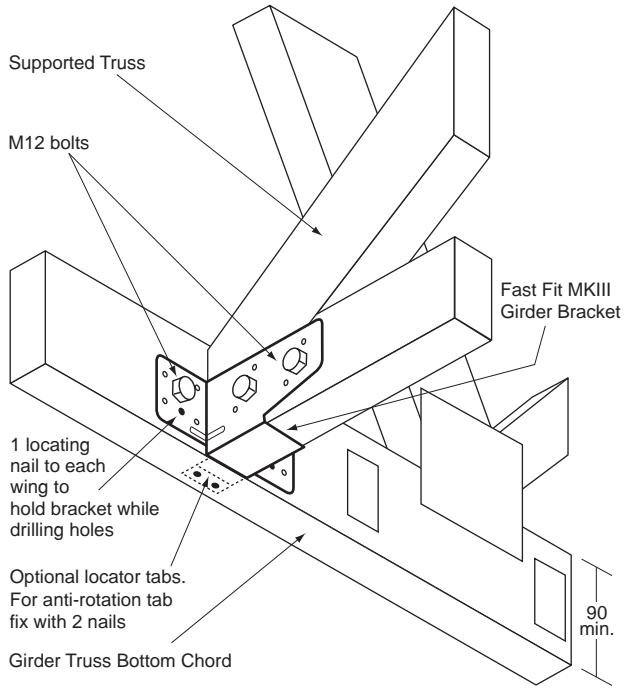

### Fast Fit MKIII - screw fitting

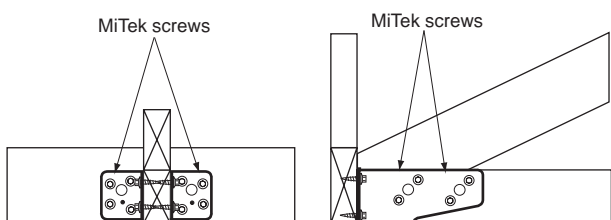
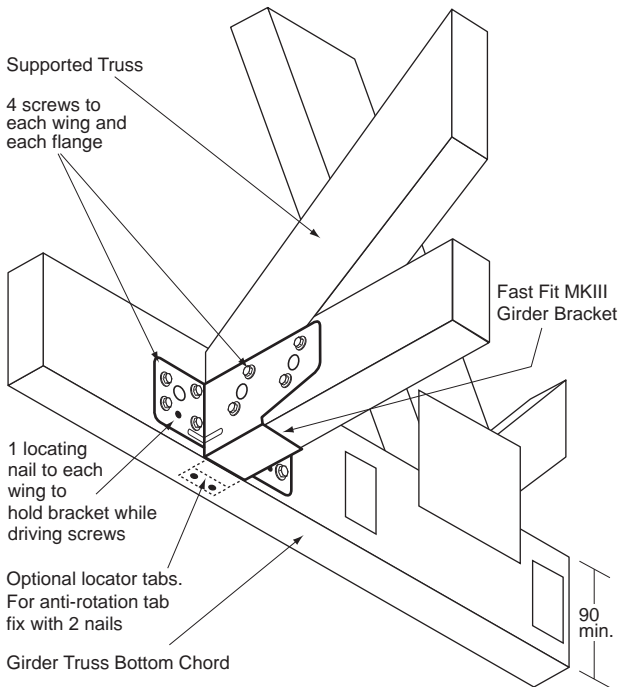

### FAST FIT MKIII - screw and bolt fitting

Fast Fit MKIII can also be installed with different fixing combinations of bolts and screws, provided the design capacities are read from the load table below.

FIXING COMBINATION	Fixing to Girder Truss	Fixing to Supported Truss	*Design Capacity
	Screw	Screw	Screw Fixing
	Screw	Bolt	Screw Fixing
	Bolt	Bolt	Bolt Fixing
	Bolt	Screw	Bolt Fixing

\* Read value off load table on page 3 of Girder Bracket Data Sheet corresponding to each fixing type.

### For Girder Bracket MK III in Cyclonic Areas.

Use 3 MiTek screws to each wing in addition to M12 bolts. Washers are also required on both sides of flanges. If length of heel plate is less than 175mm then the supported truss should be either manufactured with GQ4075 Anti Split plates, or alternatively have 3T10 Tylok Plates installed on site. (See diagram).

### Fast Fit MKIII Cyclonic

GQ4075 or 3T10 Tylok Anti-Split plates (both sides)  
10mm from end of MKIII Girder Bracket  
(If heel plate less than 175mm long).

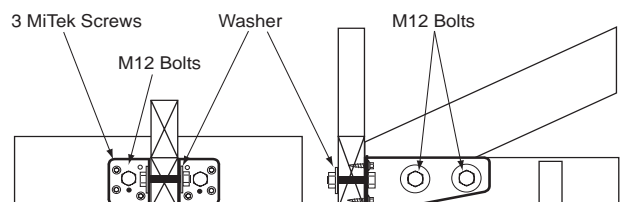
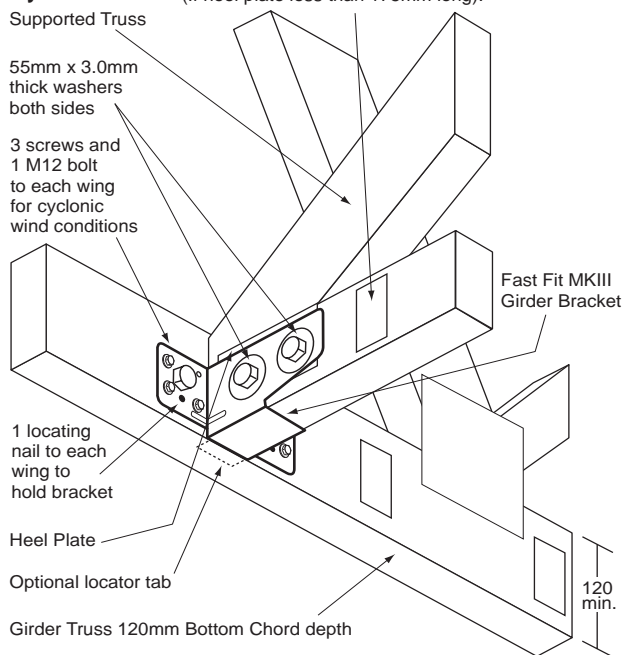

## For Girder Bracket Press On

Press On Girder Brackets are to be installed by truss manufacturer using suitable hydraulic press and tooling. Press On Girder Brackets are not suitable for on-site installation.

### Press On

Supported Truss

4 nails each side

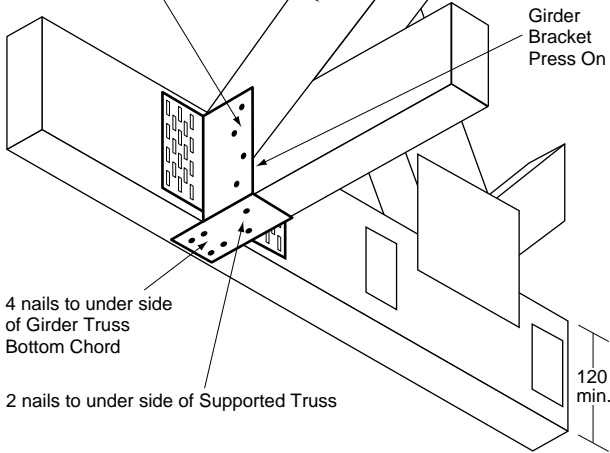

## Universal Girder Brackets

### Hi-Load Girder Bracket

Hi-Load Girder Brackets will support trusses 35mm to 90mm thick. The supported truss can also be located on either side of the cleat making the location of the bracket much simpler. The Hi-Load Girder Bracket is suitable for girder truss bottom chords of 130mm and deeper.

Hi-Load Girder Brackets are manufactured with a long cleat to prevent the twisting of the bottom chord of the girder truss. The cleat also has a cut away section which avoids the possibility of interference with ceiling linings.

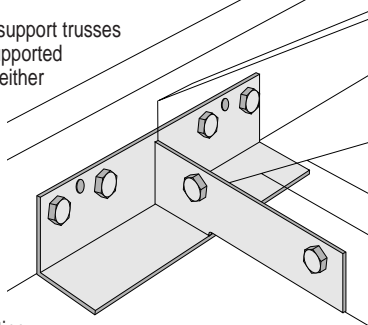

### Mid-Load Girder Bracket

Mid-Load Girder Brackets incorporate M12 bolts, therefore reducing cost and allowing the use of 100mm deep bottom chords. The supported truss may be located on either side of the cleat.

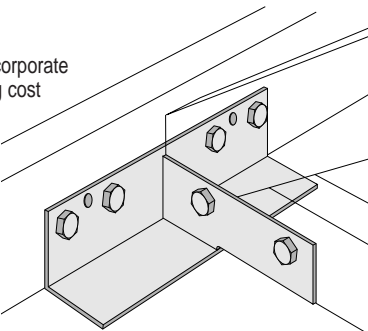

## FIXING INSTRUCTIONS FOR HI-LOAD AND MID-LOAD GIRDER BRACKETS:

1. Install the Girder Truss straight and plumb. Apply temporary and/or permanent bracing as required by design.
2. Locate bracket on Girder Truss bottom chord and fix into position by nailing through locating holes.
3. Drill through pre-punched bolt holes into Girder Truss bottom chord. Fix bracket to Girder Truss bottom chord with bolts ensuring correct washers are used to provide bearing against the timber.
4. Position Standard Truss in the bracket so that it is hard against both the cleat and the vertical leg of angle.
5. Fix truss being carried to Girder Bracket by drilling through pre-punched holes in Girder Bracket cleat.
6. Ensure washers are fitted and all bolts are tightened before loading roof.

## NOTES:

1. Holes to be drilled to suit M16 bolts for Girder Bracket Hi-Load and M12 bolts for Girder Bracket Mid-Load. Do not drill oversized holes and use hexagonal head bolts. DO NOT USE REDUCED SHANK OR CUP HEAD BOLTS.
2. Girder Truss bottom chords to be a minimum of 130 mm (nominal) for Girder Bracket Hi-Load and 90 mm for Girder Bracket Mid-Load.
3. Where ceiling is to be fixed directly to bottom chord, notching of the heel of supported trusses is recommended to obtain a better ceiling line.
4. Supported Truss bottom chords to be a minimum of 90 mm (nominal) for Girder Bracket Hi-Load.

### Hi-Load

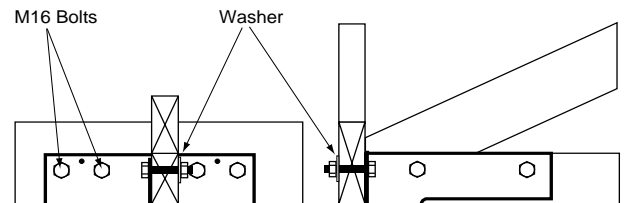
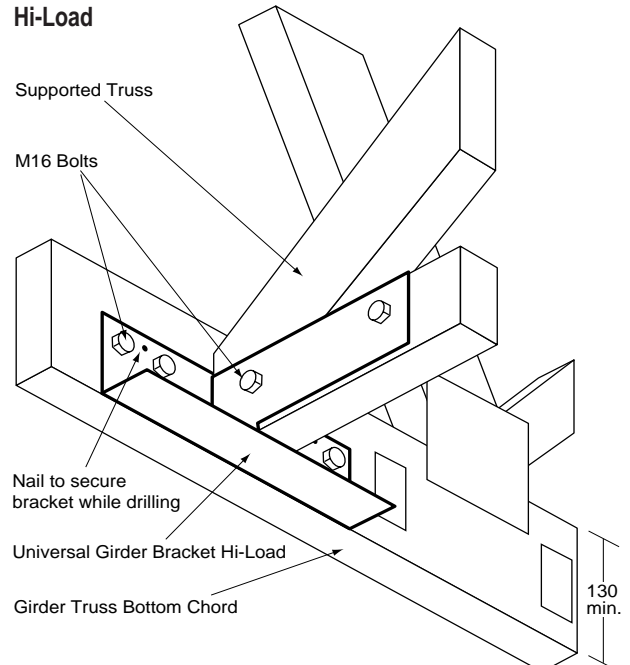

### Mid-Load

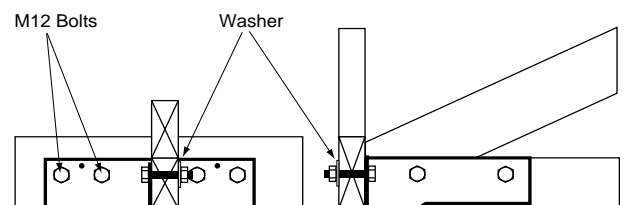
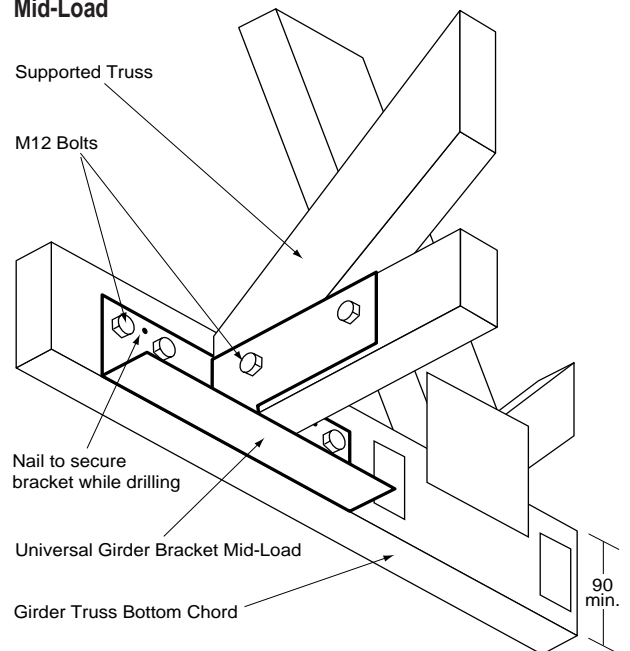

## Boomerang Girder Bracket

Specifications for Boomerang Girder Bracket are the same as Universal Hi-Load Girder Bracket except for cleat angle.

When ordering specify left hand (LH) or right hand (RH) and the angle required. Boomerang Girder Brackets are available with 22.5° or 45° cleats only. For other angles use a wedge as specified in installation instructions.

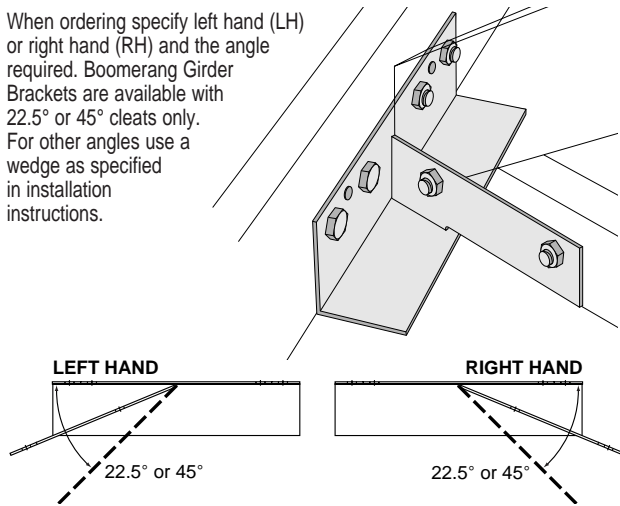

## FIXING INSTRUCTIONS FOR BOOMERANG GIRDER BRACKETS:

1. Follow steps 1 to 6 as for Hi-Load and Mid-Load Girder Brackets on previous page.
2. For trusses with intersecting angles that do not correspond to cleat angle, cut suitable dry timber wedges to match angle.
3. Install standard truss and clamp wedges on both sides as shown at right.
4. Drill through pre-punched holes and fit 2/M16 bolts.

### NOTES:

1. Holes to be drilled to suit M16 all thread bolts for Girder Bracket Boomerang. Do not drill oversized holes and use hexagonal head nuts. **DO NOT USE REDUCED SHANK OR CUP HEAD BOLTS.**
2. Where ceiling is to be fixed directly to bottom chord, notching of the heel of supported trusses is recommended to obtain a better ceiling line.
3. Supported Truss bottom chords to be a minimum of 90 mm (nominal) for Girder Bracket Boomerang.

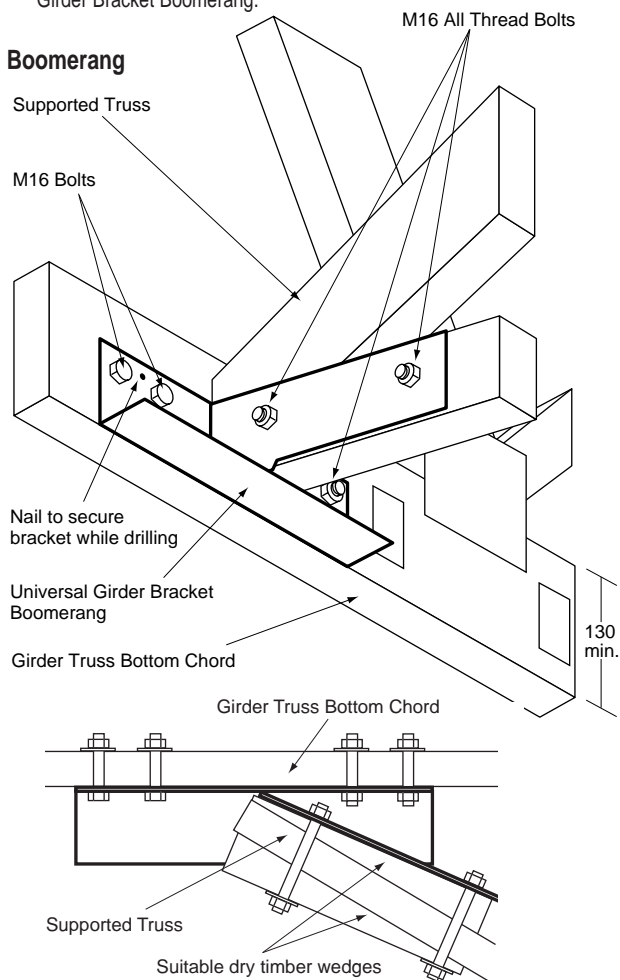

## Guardrail Systems

Where guardrails are attached to overhangs, additional overhang stiffeners may be required. The Tables 6 and 7 provide maximum unstiffened overhang distances for top chords supporting guardrail posts. Where stiffeners are required to support guardrail, the maximum overhang distance is the same as the unstiffened top chord which only supports the design roof loading.

These recommendations only apply where:

1. Trusses have been designed and manufactured by authorised MiTek fabricators.
2. Guardrail loads are as specified in AS1657-1992 'Fixed platforms, walkways, stairways and ladders-Design, construction and installation'.
3. Only one guardrail post is to be fitted to a truss overhang.
4. Maximum spacing of guardrail posts in 2400 mm.
5. A guardrail post is not to be fixed to a jack rafter whose total length is less than twice its overhang.
6. Guardrail posts are not fixed to the gable end or raking trusses. All guardrail systems used on gable ends are to restrain guardrail system loads independently of raking truss.
7. Guardrails should be fixed continuously around the corners, such as hip ends of roofs with minimum of two guardrail posts in both directions before the rail is spliced.

### Important notes:

1. *These recommendations are not suitable for supporting fall-arrest systems and devices.*
2. *Truss modifications in this sheet have been checked for top chord/jack rafter fixed guardrail systems only.*
3. *No truss members are to be cut or drilled, to enable the fixing of guardrail posts.*

## Truss Modifications

A stiffener member is to be fixed to the side of a jack rafter or truss top chord overhang at each point where a guardrail post is located and where the overhang exceeds the value in Table 6 and 7.

The stiffener is to be continuous and extend from the end of the overhang to the first panel point of the truss top chord plus 200 mm or to the entire length of a jack rafter. Refer to detail A.

Stiffener is to be the same grade as the overhang and fixed with minimum 65 mm long by 2.8 mm diameter nails, staggered to one side only as shown in Figure 1. In addition, fix two nails at the truss heel (or support point) and at ends of the stiffener. Where screws are used in lieu of nails, use minimum No. 10 gauge screws at the same spacing and pattern, provided that they penetrate a minimum of 75% into the thickness of the final receiving member.

**Table 6 - Unseasoned timbers**

**Notes:** 1. N denotes Not Suitable 2. NA denotes size is Not Available  
3. Maximum roof pitch = 35° 4. Maximum undersized 3 mm

Size	Grade			
	F8	F11	F14	F17
Maximum overhang with no stiffener required to support guardrail post				
<b>Jack rafters/trusses with sheet roof @ 900 mm max. spacing. Wind Class. N4 &amp; C2</b>				
75 x 38	N	N	N	800
75 x 50	N	800	850	950
100 x 38	650	900	1000	1100
100 x 50	900	1050	1150	1250
<b>Jack rafters/trusses with sheet roof @ 1200 mm max. spacing. Wind Class. N4 &amp; C2</b>				
75 x 38	N	N	N	700
75 x 50	N	650	700	800
100 x 38	600	750	850	950
100 x 50	750	850	1000	1100
<b>Jack rafters/trusses with terracotta tile roof @ 600 mm max. spacing. Wind Class. N4 &amp; C2</b>				
75 x 38	N	N	N	650
75 x 50	N	550	700	700
100 x 38	450	800	850	900
100 x 50	850	900	900	950

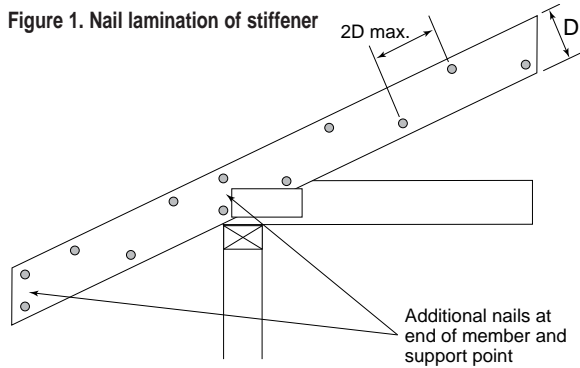

Detail A. (N.T.S.)

a) Standard truss

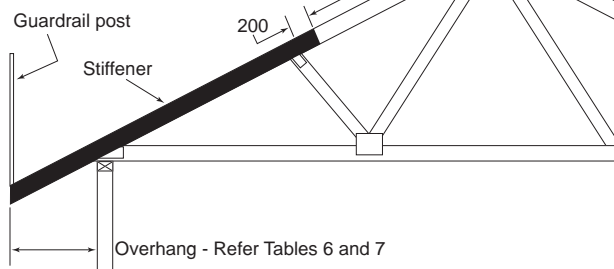

b) Truncated truss

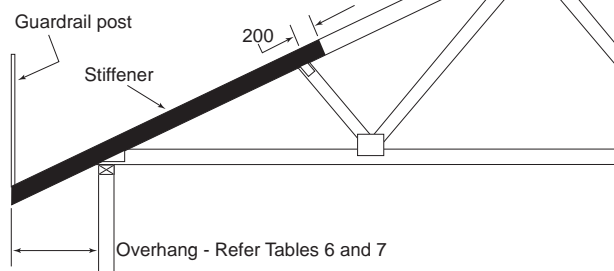

c) Jack rafter

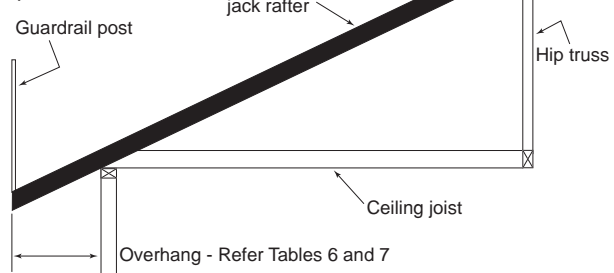

Table 7 - Seasoned timbers

Notes: 1. N denotes Not Suitable 2. NA denotes size is Not Available  
3. Maximum roof pitch = 35° 4. Maximum undersized 3 mm

Size	Grade							
	F5	F8	F11	MGP10	MGP12	MGP15	Hychord	F17
Maximum overhang with no stiffener required to support guardrail post								
<b>Jack rafters/trusses with sheet roof @ 900 mm maximum spacing. Wind Classification N4 &amp; C2</b>								
70 x 35	N	N	N	N	N	400	750	700
70 x 45	N	N	650	N	N	750	NA	800
90 x 35	N	N	800	N	700	900	950	900
90 x 45	N	750	900	N	800	1000	NA	1050
<b>Jack rafters/trusses with sheet roof @ 1200 mm maximum spacing. Wind Classification N4 &amp; C2</b>								
70 x 35	N	N	N	N	N	350	650	600
70 x 45	N	N	550	N	N	650	NA	700
90 x 35	N	N	700	N	600	750	800	800
90 x 45	N	650	750	N	700	850	NA	900
<b>Jack rafters/trusses with terracotta tile roof @ 600 mm maximum spacing. Wind Classification N4 &amp; C2</b>								
70 x 35	N	N	N	N	N	250	700	550
70 x 45	N	N	400	N	N	800	NA	800
90 x 35	N	N	850	N	650	1000	900	950
90 x 45	N	850	950	N	1000	1050	NA	1000

## Truss Installation

Trusses and jack rafters that support guardrail loads are to be installed in accordance with AS4440-1997 and with additional fixing as specified in Figure 2.

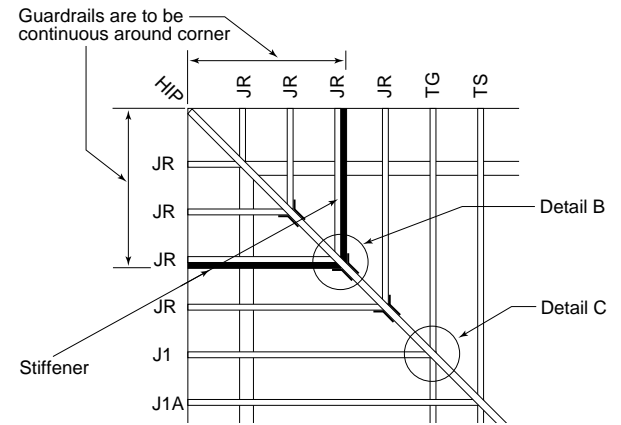
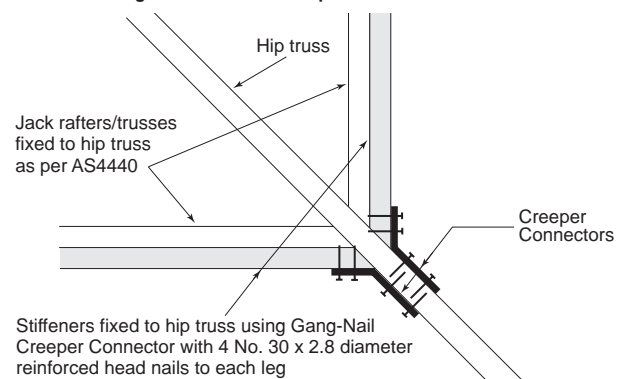
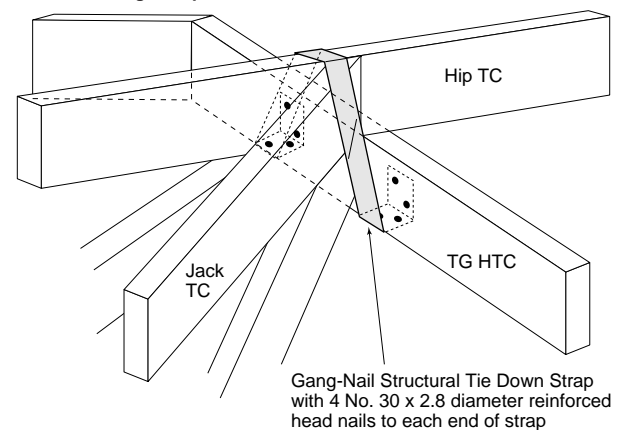

Figure 2. Truss fixings

Detail B. Fixing of Jack Rafter to Hip Truss



Detail C. Fixing of Hip Truss to Truncated Girder Truss



# TRUSS INSTALLATION CHECKLIST

When installing your roof trusses use the following checklist to ensure a quality job and to avoid overlooking any important aspects.

## Supporting Structure

- Check that all top plates that support trusses are level and straight. (Any misalignment of supporting structure will be reflected in the straightness of the roof.)
- Check that the distance between supporting walls match the spans of the trusses.
- Are the tops of internal non-load bearing walls set down below that of external load bearing walls?
- Are lintels in load bearing walls suitable for truss loading?
- Is supporting structure fully braced, plumb and stable?

## Roof Trusses

- Have trusses been stored and lifted in accordance with these instructions?
- Are trusses free of any modifications, cut members or broken members?
- Does the truss design criteria on the documentation conform to the job specification for roof cladding and special loads, eg roof mounted hot water tanks, air conditioners, etc?
- Are trusses correctly positioned according to truss layout plan?
- Are trusses accurately spaced?
- Have cantilever or internally supported trusses been orientated correctly i.e. are "Support Here" stickers located above bearing walls?
- Are trusses installed within installation tolerances?
  - (a) Plumb - All sections of truss less than 50mm or height/50 out of vertical
  - (b) Bow - All chord bows less than 50mm or chord length/200
- Are all multiple ply trusses nailed/screwed/bolted together?
- Are all waling plates fixed to truss as per design?
- Is gable end framing as per design?
- Do all trusses in corrosive environments have stainless steel plates and/or other suitable protection?

## Temporary Bracing

- Are top chord temporary ties no greater than 3000mm spacing?
- Are bottom chord temporary ties no greater than 4000mm spacing?

## Permanent Bracing

### TOP CHORD BRACING

- Is the Speedbrace configuration correct according to "Fixing & Bracing Guidelines"?
- Is the Speedbrace apex fixing correct according to "Fixing & Bracing Guidelines"?
- Is the Speedbrace fixing to each truss top chord correct according to "Fixing & Bracing Guidelines"?
- Is the Speedbrace to top plate fixing correct according to "Fixing & Bracing Guidelines"?
- Is the Speedbrace splice detail correct according to "Fixing & Bracing Guidelines"?
- Has all cantilever and web bracing been installed as per design?
- Have all web ties been installed and braced back to a rigid part of the building with cross braces?
- Are roof battens of correct size and grade?
- Are roof battens fixed to each truss including to each ply of double & triple girders using the correct size nails?
- Are roof battens spliced correctly:-
  - (a) no more than 1 in 3 on any truss?
  - (b) no 2 splices adjacent on any truss and none in unbraced zones of gable roof ends?
- Are intermediate top chord ties fixed between saddle trusses (if applicable)?

### BOTTOM CHORD BRACING

- For suspended ceilings or where furring channels are "clipped" to bottom chords:- have bottom chord ties and diagonal bracing been installed in accordance with AS4440?

## Truss Connection Details

Have trusses been fixed to top plates correctly at:-

- (a) load bearing wall i.e. Trip-L-Grip
- (b) internal non-brace wall i.e. Internal Wall Bracket
- (c) internal braced wall i.e. blocking pieces fixed in accordance with AS4440?

Have hip end components been fixed correctly at:-

- (a) jack truss to hip truss - small stations i.e. nailed
- (b) jack truss to hip truss - large station i.e. Creeper Connector
- (c) hip truss & jack trusses to truncated girder and to truncated standard truss as per AS4440
- (d) structural fascia and/or strutted overhangs?
- Are saddle trusses fixed in accordance with AS4440?
- Are standard truss to girder truss fixing type according to approved plans and are all nails/bolts installed and tight?
- Has all strengthening been completed for guard rail systems - (if applicable)



MiTek Australia Ltd. ABN 98 004 564 587

GN007-1/07

Victoria  
46 Monash Drive  
Lyndhurst 3975  
Tel: (03) 8795 8888  
Fax: (03) 9702 9464

New South Wales  
5/100 Belmore Rd  
Riverwood 2210  
Tel: (02) 8525 8000  
Fax: (02) 8525 8050

Queensland  
17 Eagleview Place  
Eagle Farm 4009  
Tel: (07) 3268 1666  
Fax: (07) 3268 2066

South Australia  
5/348 Richmond Rd  
Netley 5037  
Tel: (08) 8234 1326  
Fax: (08) 8352 4206

Western Australia  
Cnr Karel & Hope Rds  
Jandakot 6164  
Tel: (08) 9411 2845  
Fax: (08) 9411 2848

New Zealand  
Tel: (09) 274 7109

Malaysia  
Tel: (603) 3176 7473

VISIT OUR WEB SITE: [www.mitek.com.au](http://www.mitek.com.au)